

2004 5 Series

BMW
Professional
Development



2004 5 Series Product Information



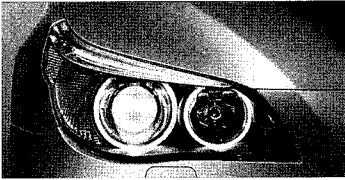

The E39 5 Series, offered from 1997 through 2003, is truly a tough act to follow, a legend in its own time. Now comes the new E60 5 Series. It will create a new legend of its own. The E60 concept, pages 2-5.

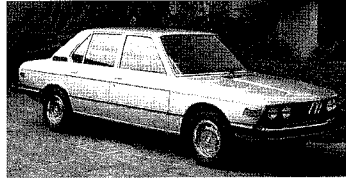

Each 5 Series generation has advanced the art of trim, sophisticated sport sedans. At left is the first-generation 5 Series; the E60 is the fifth generation. The 5 Series tradition, pages 6-7.

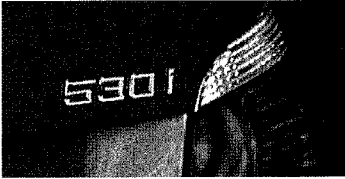

The new 5 Series consists of three models. Pages 8-10 summarize each model's key features and highlights how they differ from each other.

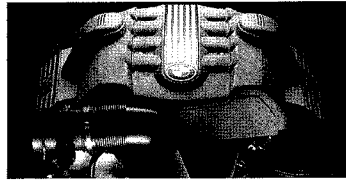

Three models. Three engine choices, with the amazing Valvetronic V-8 topping the line. Three transmission choices, all 6-speeds. Performance & efficiency features, pages 12-17.

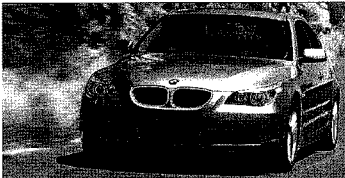

Once again, BMW introduces exciting new technology for even greater handling abilities and riding comfort. Handling, ride & braking features, pages 18-23.



Typical 5 Series character, expressed in BMW's new design language. Exterior & aerodynamics features, pages 24-27.



Contemporary elegance, more space for passengers and cargo, even greater convenience and practicality. Ergonomics, luxury & convenience features, pages 28-35.

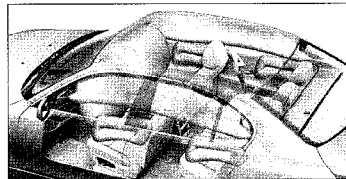

The new 5 Series embodies BMW's latest state of the art in occupant protection. Safety & security features, pages 36-39.

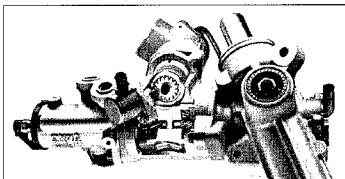

Exciting new options – among them the revolutionary Active Steering shown here. Options & accessories, pages 40-52.

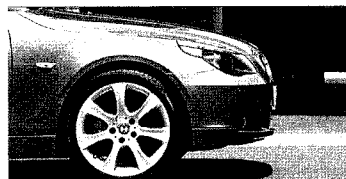

The 5 Series has long defined a BMW "sweet spot" in the market for luxury sport sedans. Marketing the new 5 Series, pages 58-64.

Table of Contents

The E60 5 Series concept	2
The 5 Series tradition	6
5 Series models	8
From the media	11
Performance & efficiency features	12
Handling, ride & braking features	18
Exterior & aerodynamics features	24
Ergonomics, luxury & convenience features	28
Safety & security features	36
Options & accessories	40
Standard & optional features summary	54
Technical specifications	56
Exterior & interior color combinations	57
Market outlook	58

Note: Because of limited art availability, some of the photos and drawings appearing in this Product Information Book are preliminary in nature. Many photos and drawings are of European models. Some information is also preliminary and subject to change.



Shown here is a 530i with Sport Package.

**The E60 5 Series concept:
worthy successors to the world's
premier midsize sport sedans.**

For seven model years, the E39 has won virtually universal praise from critics and customers alike. During 2002, its penultimate calendar year, BMW's "middle Series" defied convention by achieving higher U.S. sales – 40,842 units for calendar '02 vs. 40,005 in '01. But then, why not? The E39's awards never stopped coming: "Best Luxury Sedan under \$40,000" (525i, *Automobile Magazine's All-Stars*, February '02)...10Best (*Car and Driver*, January '02)..." Still the textbook definition of

'midsize sport sedan'" (*Motor Trend*, February '02) ...winner of 7-car comparison test (540i Sport, *Car and Driver*, September '01) ...winner of 4-car comparison test (540i, *Motor Trend*, September '01)...honored in Strategic Vision's new Total Delight awards for 2003. So, indeed a tough act to follow. But BMW knows how to follow tough acts; the new E60 platform proves this once again. Beginning with 7/03 production, three E60 Sedan models will be phased in to form the 2004 5 Series.



Tough act to follow: the E39 5 Series, 1997-2003. To follow a legend like this, the E60 has to be good.

Excitingly new – yet utterly in the 5 Series tradition

Take a look at those lines. The new 5 is every bit as new as the new 7 Series was when it made its debut a year ago, and yet it is absolutely not a scaled-down version of the 7. It takes BMW's "new look" to another vehicle category, yet upon the very first glance one knows that it's a BMW 5 Series.

Incrementally larger and roomier, yet still trim

Riding on a wheelbase that's 2.3 inches longer than before, the new Sedans are 2.6 in. longer and 1.8 in. wider than their pred-

ecessors. Incorporating an industry-wide trend, they are also 1.3 in. taller. These dimensional gains result in greater rear seating space and comfort. Entry into the rear seating compartment is easier; there's also substantially more trunk space. And yet the new 5 preserves the trim look and driving feel, the maneuverability and agility that have always been a core value of the 5 Series. Contributing to this notable achievement is an all-aluminum front end that allows the size increase, comfort and safety advances, and enhanced content with actual decreases, for most models, in overall vehicle weight.

E60 vs. E39 5 Series Sedan Key dimensions & weights

	E39	E60	Difference
Wheelbase, in.	111.4	113.7	+2.3
Track, front/rear, in. (standard wheels)	59.5/60.1	61.3/62.1	+1.8/2.0
Length, in.	188.0	190.6	+2.6
Width, in.	70.9	72.7	+1.8
Height, in. (without Sport Package)	56.5	57.8	+1.3
Weight, lb. (preliminary data for E60):			
525i with automatic transmission	3505	3450	-55
540i/545i with automatic transmission	3803	3814	+11
Weight distribution, front/rear, %:			
525i with automatic transmission	50.6/49.4	50.5/49.5	0.1
540i/545i with automatic transmission	52.5/47.5	51.1/48.9	1.4
Shoulder room, front/rear, in.	56.8/55.9	57.3/57.2	+1.5/1.3
Head room with moonroof, front/rear, in.	37.4/37.2	37.7/37.9	+0.3/0.7
Leg room, front/rear, in.	41.7/34.2	41.5/36.0	+0.2/1.8
EPA interior volume, cu ft.	92.5	99.1	+6.6
EPA cargo volume, cu ft.	11.1	14.0	+2.9

Compared to the E39 5 Series, the E60 has grown incrementally in nearly all key dimensions.

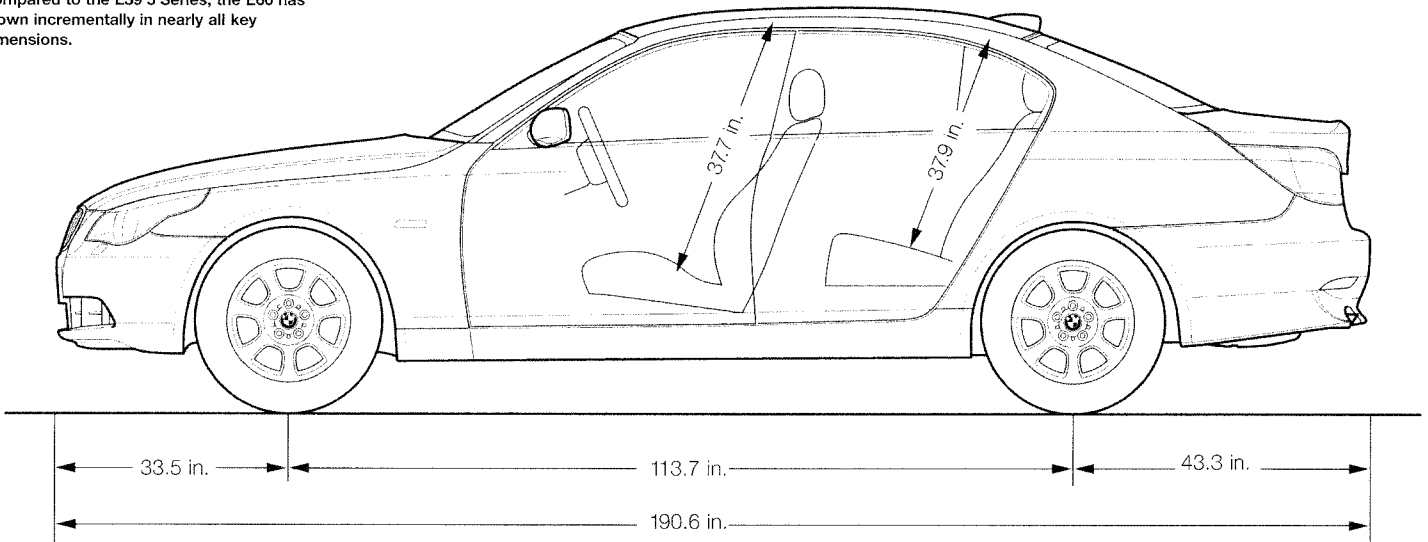

Technological innovations with wide-ranging relevance

A new BMW platform always means exciting new technology – technology that is fascinating in its own right, yet also meaningful to owners, drivers and passengers. Among the 5 Series' brand-new technologies are Active Steering¹, two evolved versions of iDrive (one optional), and a Head-Up Display¹; new technologies already seen in other BMW models and making their first appearance in the 5 Series include the Valvetronic V-8 engine (545i), 6-speed automatic transmission¹, Sequential Manual Gearbox¹, Active Roll Stabilization¹, Xenon Adaptive headlights², Adaptive brakelights, run-flat tires¹, telematics and Voice Command System¹.

Three models, extensive powertrain choices

The E60 5 Series launches with three models, each powered by a specific engine. The **525i Sedan** continues with the engine of its predecessor, the responsive and impressively fuel-efficient 2.5-liter, 184-hp inline 6-cylinder. Production begins in 9/03. The **530i Sedan**, whose production begins in 7/03, again offers upgraded 6-cylinder power (3.0 liters, 225 hp) and some additional standard equipment. And the **545i Sedan** derives its model designation from the remarkable Valvetronic engine first introduced in the 7 Series: a 4.4-liter V-8 delivering 325 hp. That's up 35 hp over the previous 540i models.

All manual transmissions are 6-speeds. Both 6-cylinder models come standard with the ZF Type H transmission seen first in the Z4, then in the latest 3 Series 330 models; this unit weighs no more than the 5-speed it replaces and features ultra-precise, short-throw shifting. As before, the V-8 model is offered in two versions: 6-speed manual, with standard Sport Package equipment; and automatic, with which the Sport Package is offered as optional equipment. Here the manual transmission is the new ZF Type G, making its first appearance with the same advanced features as the Type H but higher torque capacity for the V-8 engine.

All automatic transmissions are also 6-speeds with STEPTRONIC. The new ZF 6HP19 makes its debut in the 525i and 530i; the 545i's ZF 6HP26 is shared with the 7 Series. And as the "third way," the 6-speed Sequential Manual Gearbox (SMG) is offered in combination with the Sport Package as of 9/03 production on the 530i and 545i, as of 3/04 production on the 525i.

Are you counting? That's a total of **9 powertrain choices** to suit every buyer preference.

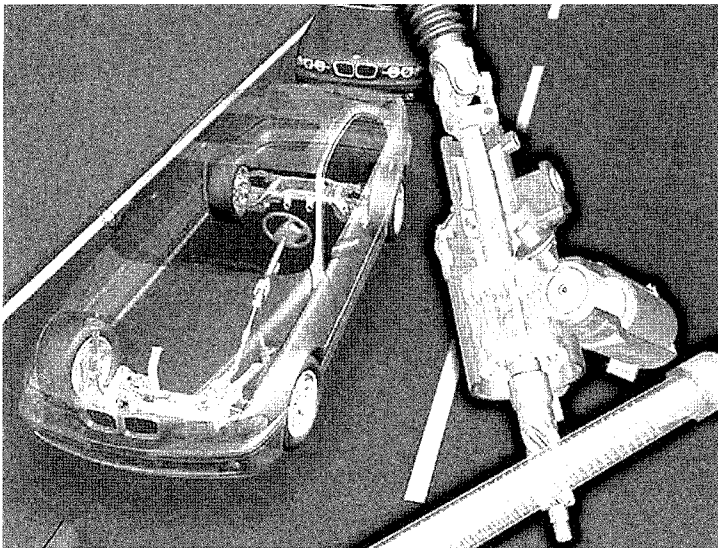

Among the E60's many Unique Selling Points, Active Steering (shown) is the most revolutionary. Other prominent USPs include the Valvetronic V-8 engine and the available Sequential Manual gearbox, Xenon low- and high-beam Adaptive headlights and the ergonomically beneficial Head-Up Display.

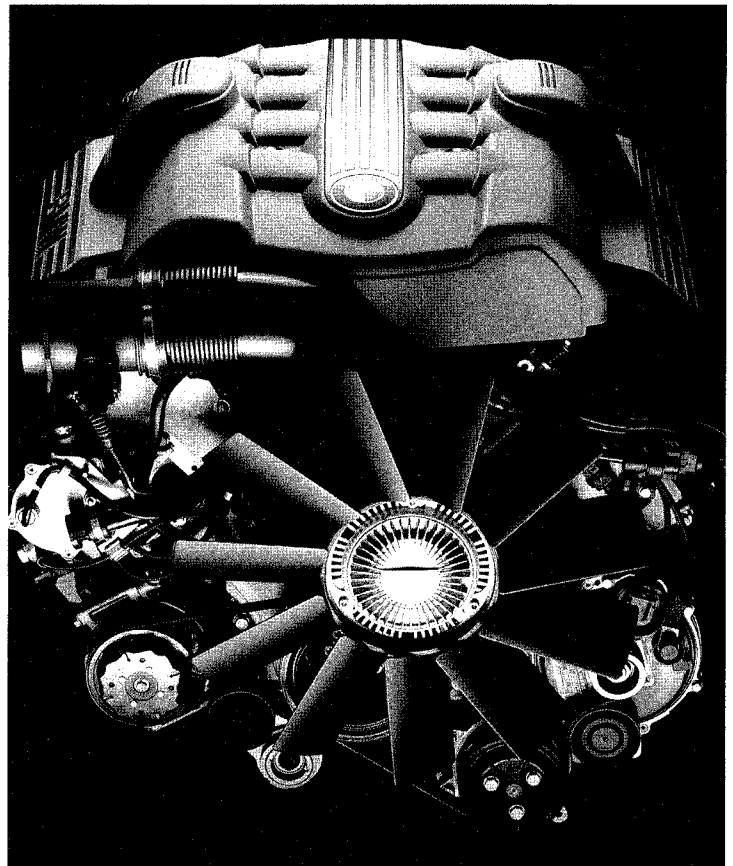

In the trim, weight-efficient 545i, BMW's amazing 4.4-liter, 325-hp Valvetronic V-8 engine delivers class-leading performance.



Further developed road capabilities

The E39 5 Series was already an exemplar of how a carmaker can combine outstanding handling with amazing riding comfort. The E60 takes this kind of excellence to another level, ensuring that BMW remains at the head of its class when it comes to road capabilities.

Although the basic chassis technology remains the same as before, the E60 departs from its predecessor in several significant ways. All models now share essentially the same aluminum suspension and subframe and rack-and-pinion steering system; 6-cylinder E39s had this system but V-8 E39s had a heavier steel subframe and recirculating-ball steering. Thus the 545i now shares in full measure the handling and comfort benefits of reduced unsprung weight, further reduced overall weight, and the extra steering precision of rack-and-pinion.

Two new features make every Sport Package-equipped E60 even sportier, more agile and yet more confident in its handling: Active Steering and Active Roll Stabilization. The tires of all Sport Packages are performance run-flats. And 17-in. wheels and tires are newly standard on the 530i and the automatic-transmission V-8 model.

Contemporary ambiance, plus intelligent comfort and convenience features

BMW Design has done it again: The interior radiates an all-new ambiance, ultra-contemporary and yet reassuring and intuitive. Harmonious lines sweep across the dash; the doors are attractive and, with their large door

pulls, pleasantly functional. Key elements of BMW tradition remain: the center console is oriented toward the driver, even though the controller there is easily reached by the front passenger. A pull-up handbrake is retained, and is of course oriented toward the driver. Materials and colors offer new choices, such as the available gray-tone Maple Anthracite wood trim and an Auburn color scheme.

BMW's newest advances in safety engineering

The E60 5 Series builds upon safety-oriented progress introduced in the E65 7 Series. The safety-device control system, called ISIS (Intelligent Safety and Information System) as with the

The E39's combination of excellent handling and supple riding quality was remarkable. With its increased use of aluminum in the body and chassis, suspension and steering refinements, and the additional innovations included in the available Sport Packages, the E60 delivers an even more remarkable constellation of road qualities.

7 Series, deploys all safety systems optimally. In addition to the front-impact airbags and front-door side-impact airbags, the doors incorporate BMW's proven door interlocking system for side impacts. As in the 7 Series, the front and rear Advanced Head Protection System (AHPS II) is also standard. Rear-door side-impact airbags continue as an option, newly augmented by automatic tensioners for the outboard rear safety belts.

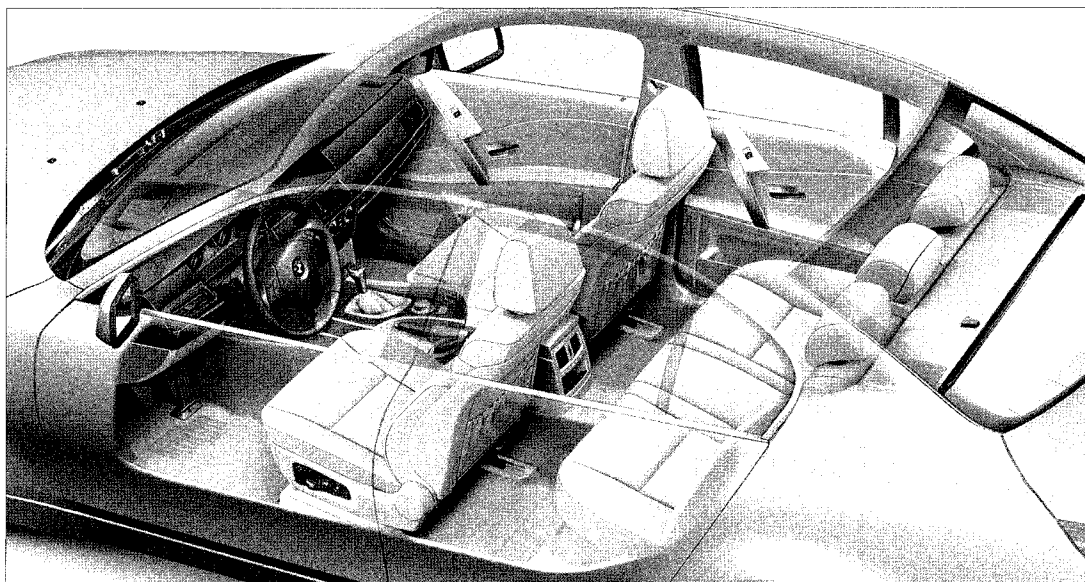

The E60 cabin is clearly BMW, clearly a Five, and full of design and functional innovations.



As a total break from any BMW to date, the 1500, introduced in 1961, was called the New Class. It was exactly that: the “middle” car that BMW needed to prosper and grow, and the first lineal ancestor of the 5 Series.



As the successor to the 1500 and its derivatives, the new sedan Series of 1972 (E12) was available in 520 and 520i models, and was thus the first so-named 5 Series. This is a 1975 530i, which was the first 5 Series model to be offered in the U.S.

The 5 Series tradition: historic “middle” of the BMW line

The 5 Series’ lineage actually begins before the designation “5 Series” was introduced.

At the end of World War II, BMW’s original automobile factory was lost to Soviet-controlled East Germany, so BMW had to start over again, from virtual scratch. Not until 1951 was BMW able to introduce its first postwar car model, produced in Munich in a rebuilt factory that had made motorcycles before the war.

The early postwar BMWs were a mixture of large and/or expensive models (6- and 8-cylinder sedans; 8-cylinder coupes, convertibles and sports cars) and tiny rear-engine vehicles based to a large extent on 2-cylinder motorcycle powertrains (Isetta, 600, 700). The large and/or expensive models had very limited volume potential, and as postwar European economies recovered from the war, the market for tiny cars like the Isetta gradually faded away.

Thus as early as the mid-1950s, BMW management recognized the need for a “middle” car.



With the 2nd-generation 5 Series (E28, top), BMW essentially "re-skinned" the 1st-generation body, but also incorporated many engineering improvements. This is a 1987 535is, the "s" meaning a sport version.

The 3rd-generation 5 Series (E34, just above) was a dramatic step forward, with very graceful styling and yet also more passenger space and new safety engineering. This is a 1995 530i Sedan; beginning in '92, a "touring" (Sport Wagon) body was also offered.



The E39 5 Series, still riding high on critical acclaim, was introduced for the 1997 model year and concludes its production run in 2003.

This new "middle" car was introduced in 1961 to great fanfare. Called the New Class or, referring to its engine size, the 1500, it was a 4-door sedan, middle-sized by European (and outright small by U.S.) standards. There was an Italianate flair to its design, and it embodied highly progressive engineering features: overhead-camshaft engine (4 cylinders), strut-type front suspension, a new kind of independent rear suspension. In due course the New Class added models with larger engines. A smaller 2-door "02" series was derived; it became legendary as the 2002. There was even a sporty coupe. By the time production of the original 4-door body ended in 1972, BMW was once again a healthy, prosperous company with a bright future ahead of it.

The first 5 Series, 1972-82

When the successor to the New Class was introduced in 1972, it was called the 520. At the '72 Frankfurt Auto Show, it was explained to the press that the "5" stood for the vehicle type and the "20" for its engine size, and that BMW intended to apply this naming system to future models. To this day, BMW has remained true to the system for its mainstream Series; even the Series that express today's greater diversity of vehicle types (M3, Z4, M5, X5, Z8) retain the numeral as a reference to their positions in the BMW line.

From the original 520 (carbureted) and 520i (fuel injection) sprang a variety of models over the life of this first 5 Series, whose platform was designated E12. Alongside the original 4-cylinder 520 models came the first 6-cylinder 5 Series models, the 525 and 528, and in 1975 the first model for the U.S., the 530i. Other variations, including the high-performance M535i, carried the original "Five" up to its phase-out in 1982.

In the meantime, BMW had purchased another carmaker's factory in Dingolfing, northeast of Munich, to meet the growing demand for the 5 Series. The year 1975 saw the 3 Series introduced as BMW's new compact line; the 6 Series luxury-sport coupes followed in 1976, and in 1977 the 7 Series put BMW into the top luxury category.

More than a facelift: E28 5 Series, 1981-88

From the outside, the E12's successor appeared to be a facelift. But a lot of engineering work had been done – "intelligent lightweight construction" reduced its weight while increasing its strength; most of its outer skin was new and subtly updated.

This E28 5 Series came to the U.S. in 1982 as a single model, the 528e with an innovative, efficiency-tuned 6-cylinder engine; a year later the performance-oriented 535i followed. For a single model year (1988) there was an even more muscular M5

model, the first M Car officially offered in the U.S.; and in 1985-86 BMW even offered a turbodiesel 524td model. The E28 5 Series had its last model year in 1988.

Dramatic step forward: E34 5 Series, 1989-95

The next 5 Series was a more dramatic move. Its body was more graceful and stylish, yet also enclosed more passenger space and achieved greater occupant safety. Offered only with 6-cylinder engines, it began in the U.S. as 525i and 535i models, then added a new-generation M5 in '91. During the E34's lifespan, the dual-overhead-camshaft, 24-valve 6-cylinder engine was introduced into regular (i.e. non-M5) production, and a "touring" model (station wagon) was added. In 1994, V-8 engines were added: the 530i and 540i.

"The best car we've tested": E39 5 Series, 1995-2003

Though not a breakaway in the sense of the new E60, the E39 5 Series was (and remains) captivating with its sporty roofline, forward-leaning "crouch" stance and singular combination of elegance and aggressivity.

Under the lovely skin, there was also much to be excited about. A revolutionary aluminum suspension system helped save overall vehicle weight, but more importantly it enabled BMW engineers to create an almost unbelievably supple, compliant and yet firm-handling road machine.

Consisting of 6-cylinder 528i and V-8 540i models, the E39 5 Series came to the U.S. in 1997. A "touring" body style, now called Sport Wagon in the U.S., was added in 1999 and offered with both engines. In 2001, BMW enlarged the 528i's 2.8-liter engine to 3.0 liters to create the 530i sedan, and added 525i Sedan and Sport Wagon models to achieve a lower price point.

During the E39's tenure, the media have heaped unending praise on all 5 Series models; for a sample, see **Fast Facts 2003-2004**, pages 98-99. The quote at left is from a source that may not be cited.

The diversity of today's BMW line is a far cry from BMW's narrow offerings in 1962, when the 5 Series' first lineal ancestor appeared. These days, it's not just sedans – but sedans, coupes, sport wagons, convertibles, 2-seater roadsters and even Sports Activity Vehicles – among which the 5 Series remains the "middle" of the line, if not quite as straightforwardly as a decade ago. In this setting, the 5 Series finished calendar '02 behind only the 3 and X5 Series in volume.

In a strict naming sense, the E60 is the 5th-generation 5 Series. It continues – and advances – a proud tradition of practical, yet spirited sport sedans begun more than 40 years ago.



Chrome vertical grille slaps are a differentiating feature of 545i models.

5 Series models

Key features



525i

The most accessible 5 Series model.

Performance & efficiency

- 2.5-liter DOHC 24-valve inline 6-cylinder engine with Double VANOS¹ steplessly variable intake- and exhaust-valve timing, 184 hp
- Standard 6-speed manual transmission, optional 6-speed STEPTRONIC automatic transmission or 6-speed Sequential Manual Gearbox (SMG)²

Handling, ride & braking

- Aluminum front-end structure for reduced overall vehicle weight and optimum weight distribution
- Aluminum double-pivot-type front suspension
- Aluminum 4-link Integral rear suspension
- Engine-speed-sensitive power rack-and-pinion steering

- 4-wheel ventilated disc brakes
- Dynamic Stability Control
- 16 x 7.0 lightweight forged-alloy wheels, Trapezoid design (#134)
- 225/55R-16 V-rated all-season tires
- Flat Tire Monitor

Exterior & aerodynamics

- All-new exterior design
- 4-headlight system with halogen free-form lamps
- Automatic headlight control
- Halogen free-form front foglights
- Rain-sensing windshield wipers
- Adaptive brakelights
- Choice of standard or metallic paint at no extra cost
- "525i" script on trunklid

Ergonomics, luxury & convenience

- All-new interior design with increased rear seating space
- Vehicle and Key Memory with expanded functions
- Keyless entry with multi-function remote control
- Dual power/heated exterior mirrors with automatic tilt-down of right mirror for visibility of curb when backing up
- BMW Ambiance Lighting
- Power tilt/telescopic leather-wrapped 3-spoke steering wheel with fingertip multi-function controls, automatic tilt-up for entry & exit

- Cruise control
- 10-way power front seats with power head restraints
- Dual center console compartments with climate-controlled lower compartment
- iDrive control system
- Telematics
- Leatherette upholstery and Titanium-finish interior trim
- Ruthenium-finish interior trim (door pulls and interior door handles)
- Power windows with key-off operation, 1-touch opening & closing, anti-trapping feature, opening from remote, closing from exterior lock
- Automatic climate control with full separate left/right controls, humidity control, bi-directional solar sensor and other features
- Activated-charcoal microfilter ventilation
- 2-way power moonroof with newly expanded 1-touch functions and larger opening area
- Anti-theft AM/FM/CD audio system with Radio Data System, 10 speakers (including 2 subwoofers)
- Pre-wiring for BMW Cellular Phone System and glove-compartment-mounted 6-disc CD changer

- Power outlets in front passenger's footwell, aft end of center console, and trunk
- Dual cupholders front and rear
- Fold-up rear center armrest
- Interior trunk release, electrically operated
- Fully finished trunk with increased cargo capacity, drop-down toolkit

Safety & security

- Intelligent Safety and Information System (ISIS) for control of safety systems and devices
- Dual-airbag Supplementary Restraint System with 2-stage Smart Airbags
- 3-point safety belts at all seating positions
- Front safety belts with automatic tensioners and force limiters
- Interlocking door anchoring system for side impacts
- Front- and rear-seat Head Protection System (AHPS II)
- Front-seat side-impact airbags
- Central locking system with double-lock anti-theft feature, selective unlocking
- Coded Driveway Protection
- Alarm system with operation from remote, interior motion detector

Options

- Premium Package:
 - Dakota leather upholstery
 - Dark Poplar wood interior trim (Maple Anthracite available at no extra cost in combination with Package)
 - Upgraded exterior/interior lighting amenities (Design Light Package)
 - 4-way power front-seat lumbar support
 - Auto-dimming exterior and interior mirrors
 - BMW Universal Transceiver
- Sport Package:
 - Active Steering
 - Active Roll Stabilization
 - Sport suspension calibration
 - 17 x 8.0 alloy wheels, Star Spoke design (#122)
 - 245/45R-17 W-rated run-flat performance tires
 - Shadowline exterior trim
 - 12-way power front sport seats

- Cold Weather Package:
 - High-intensity headlight cleaning system with retractable jets
 - Heated front seats with balance control via iDrive system
 - Heated steering wheel
- Premium Sound Package:
 - Logic 7 audio system with increased audio power, 13 premium speakers (including 2 subwoofers), Surround Sound simulation and Digital Sound Processing
 - Glove-compartment-mounted 6-disc CD changer
- Rear-seat Entertainment Package (available as of 3/04 production)
 - Video monitor for rear passengers
 - Trunk-installed 6-disc multimedia changer
 - Wireless headphones
 - Remote control
 - Input jack for external sources

Stand-alone options:

- 6-speed STEPTRONIC automatic transmission
- 6-speed Sequential Manual Gearbox² (available as of 3/04 production)
- Active Cruise Control
- Park Distance Control
- Xenon Adaptive headlights with dynamic auto-leveling
- Head-up Display
- Dakota leather upholstery
- 20-way front Comfort seats
- 4-way power front-seat lumbar support
- Split folding rear seats and ski bag
- Heated rear seats (require Cold Weather Package)
- BMW On-board Navigation System with expanded iDrive functions and Voice Command System
- Sirius Satellite Radio
- Power rear-window and manual rear side-window sunshades
- Maple Anthracite wood interior trim³
- Rear-seat side-impact airbags and automatic tensioners on rear outboard safety belts



530i

Premium 6-cylinder model, with higher performance and more extensive standard equipment.

In addition to or in place of the features listed for the 525i, the 530i includes:

Performance & efficiency

- 3.0-liter DOHC engine, 225 hp

Handling, ride & braking

- 17 x 7.5 cast-alloy wheels, Star Spoke design (#138)
- 225/50R-17 V-rated all-season tires

Exterior & aerodynamics

- "530i" script on trunklid
- Different wheel design and wheel/tire dimensions

Options

(all options are listed)

- Premium Package: same contents as for 525i
- Sport Package: same contents as for 525i, except –
 - 18 x 8.0 alloy wheels, Star Spoke design (#123)
 - 245/40R-18 W-rated run-flat performance tires

- Cold Weather Package: same contents as for 525i
- Premium Sound Package: same contents as for 525i
- Rear-seat Entertainment Package: same contents as for 525i

Stand-alone options:

- 6-speed STEPTRONIC automatic transmission
- 6-speed Sequential Manual Gearbox² (available as of 9/03 production)
- Active Cruise Control
- Park Distance Control
- Xenon Adaptive headlights with dynamic auto-leveling
- Head-up Display (available as of 9/03 production)
- Dakota leather upholstery
- 20-way front Comfort seats
- 4-way power front-seat lumbar support
- Split folding rear seats and ski bag
- Heated rear seats (require Cold Weather Package)
- BMW On-board Navigation System with expanded iDrive functions and Voice Command System
- Sirius Satellite Radio
- Power rear-window and manual rear side-window sunshades
- Maple Anthracite wood interior trim³
- Rear-seat side-impact airbags and automatic tensioners on rear outboard safety belts

1 – VANOS = VAriable NOckenwellen Steuerung = variable camshaft control, or variable valve timing.

2 – SMG requires Sport Package.

3 – No-cost option; requires Premium Package.

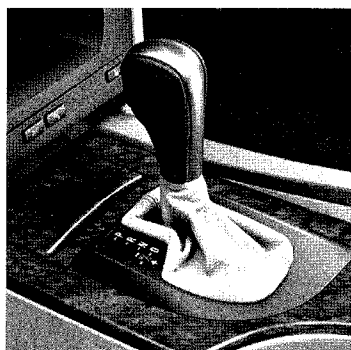

545i

V-8 model, top of the line. Offered in two versions: 545i (with automatic transmission standard) and 545i 6-Speed (with 6-speed manual transmission and sport equipment standard). This is the version with automatic transmission.

In addition to or in place of the features listed for the 530i, the 545i includes:

Performance & efficiency

- 4.4-liter DOHC (4-cam) 32-valve V-8 engine with Valvetronic variable intake-valve lift and steplessly variable intake system, 325 hp
- Standard 6-speed STEPTRONIC automatic transmission, optional 6-speed Sequential Manual Gearbox²

Handling, ride & braking

- Same-size 17-in. cast-alloy wheels, but Star Spoke design (#116)

Exterior & aerodynamics

- "545i" script on trunklid
- Different wheel design
- Xenon Adaptive headlights with dynamic auto-leveling, standard
- Chrome vertical grille slats (525i and 530i: black)

Ergonomics, luxury & convenience

- Dakota leather upholstery, standard
- Dark Poplar wood interior trim, standard
- 2-way power moonroof, standard

Options

(all options are listed)

- Premium Package not offered because all Package contents except power lumbar support are standard
- Sport Package: same contents as for 530i, except –
 - 18 x 8.0 front/18 x 9.0 rear alloy wheels, Star Spoke design (#124)
 - 245/40R-18 front / 275/35R-18 rear W-rated run-flat performance tires
- Cold Weather Package: same contents as for 525i
- Premium Sound Package: same contents as for 525i
- Rear-seat Entertainment Package: same contents as for 525i

Stand-alone options:

- 6-speed Sequential Manual Gearbox²
- Active Cruise Control
- Park Distance Control
- Head-up Display
- 20-way front Comfort seats
- 4-way power front-seat lumbar support
- Split folding rear seats and ski bag
- Heated rear seats (require Cold Weather Package)
- BMW On-board Navigation System with expanded iDrive functions and Voice Command System
- Sirius Satellite Radio
- Power rear-window and manual rear side-window sunshades
- Maple Anthracite wood interior trim, no-cost option
- Rear-seat side-impact airbags and automatic tensioners on rear outboard safety belts



545i 6-Speed

V-8 model, top of the line. Offered in two versions: 545i with automatic transmission, at left; and this 545i 6-Speed (with 6-speed manual transmission and Sport equipment standard).

In addition to or in place of the features listed for the 545i, the 545i 6-Speed includes:

Performance & efficiency

- Standard 6-speed manual transmission, optional 6-speed Sequential Manual Gearbox (SMG)

Handling, ride & braking

- Active Steering, standard
- Sport suspension calibration, standard
- Wheel/tire equipment of 545i Sport Package is standard:
 - 18 x 8.0 front/18 x 9.0 rear alloy wheels, Star Spoke design (#124)
 - 245/40R-18 front / 275/35R-18 rear W-rated run-flat performance tires
 - Flat Tire Monitor

Exterior & aerodynamics

- Different wheel design and wheel/tire dimensions
- Shadowline exterior trim, standard

Ergonomics, luxury & convenience

- 12-way power front sport seats, standard

Options

(all options are listed)

- Sport Package not offered because its contents are standard on this model
- Cold Weather Package: same contents as for 525i
- Premium Sound Package: same contents as for 525i
- Rear-seat Entertainment Package: same contents as for 525i

Stand-alone options:

- 6-speed Sequential Manual Gearbox
- Active Cruise Control
- Park Distance Control
- Head-up Display
- 20-way front Comfort seats
- 4-way power front-seat lumbar support
- Split folding rear seats and ski bag
- Heated rear seats (require Cold Weather Package)
- BMW On-board Navigation System with expanded iDrive functions and Voice Command System
- Sirius Satellite Radio
- Power rear-window and manual rear side-window sunshades
- Maple Anthracite wood interior trim, no-cost option
- Rear-seat side-impact airbags and automatic tensioners on rear outboard safety belts



From the media

Experts from many lands praise the new 5.

All models

"As you can see from these photos, the elegant interior is clearly related to the 7 Series cabin, most notably with the beautifully integrated twin instrument canopies and the avant-garde applications of wood and plastics."

Automobile Magazine, June 2003

"We drove a 530i with a six-speed manual on the slalom and had a great time. The manual [transmission] feels a little heavy, but considering all the torque routed through it, that was forgivable. We spent most of the next day in a six-speed automatic, which was also fun on the winding, diving skinny strings of blacktop fettuccini that pass for roads in Sardinia."

"Ultimately, the new 5 Series is still incredibly fun to drive. Its balance is almost unmatched in the segment, the engine choices have never disappointed and overall engineering has been the benchmark in the industry."

AutoWeek, May 26, 2003

"In this class of car, the rear-wheel drive really can meet high demands better than front-wheel drive. The smoothness of the 5 Series over bumps, the defined precision of the suspension reactions, the absolute quietness of the rear axle, which goes about its job without any thumping, the

superb damping of noise – this is obviously a domain of the Bavarians that no other manufacturer can occupy."

Frankfurter Allgemeine Zeitung, Germany, May 20, 2003

"Thanks to the aluminum suspension with its multi-link rear axle like the 7 Series, the car swallows up any road imperfections as if there were no connection between wheel and bodywork."

Auto Bild, Germany, May 16, 2003

"A substantial automobile has been created here, standing robustly on its wheels – an impression to which its wide tracks and short front overhang contribute a full measure."

"The two 'waves' of the instrument panel, sweeping over the round dials and the iDrive monitor, form a graceful unit. And the controls are arranged as one expects in a BMW: understandable without an orientation course."

"The 5 is significantly larger than its predecessor, making for a totally new feeling of space inside."

"A flawless seating position and very comfortable seats, front and rear, ensure that one immediately feels good in the 5. The power-window controls' ergonomic arrangement catches your eye; the round instruments present themselves

with typical BMW clarity. Information on the monitor reads well, even in strong sunlight."

"The effect [of the Active Steering] is astonishing. In parking, it takes fewer than two turns lock-to-lock, making it easier to maneuver into tight parking places. On curving roads as well, the new steering makes a very good first impression: The 5 reacts spontaneously and with great precision to the smallest steering inputs and gives the impression of driving a much smaller vehicle. In the upper middle class, there is currently no competitor that can be driven so nimbly and effortlessly."

"The new 5 lends new meaning to the old BMW slogan 'the joy of driving'; this is due to not just the Active Steering, but also the harmonious aluminum suspension. Neutral handling over a wide range plus high cornering power give the driver confidence and make road curves a pleasure."

"Despite its sporty driving character, this new BMW doesn't sacrifice comfort. The steel springing does its job so well that one never wishes for air suspension, as offered by the Mercedes E-Class."

"The 5 soaks up road irregularities without any bothersome vertical movements of the body."

In addition, the suspension responds nicely and keeps road noise low on to bad surfaces. This is surprising, given the fact that all the optional tires are run-flats."

"Both engines' harmonize very well to either the standard, very precise-shifting 6-speed manual transmission or the smooth and quick-reacting 6-speed automatic."

"Not cheap, but genuine pleasure."

auto motor und sport, Germany, May 14, 2003

"How technology has become fun again...Currently, there is no better steering, no other system that simultaneously communicates such a high degree of adhesion to the road with a feeling of lightness which, when needed, then moves into a heightened precision mode of road-hugging safety."

Frankfurter Allgemeine Zeitung, Germany, April 8, 2003, in an article devoted solely to Active Steering

530i

"So, a lot that's new, but also a lot that's familiar: for example the 530i 6-cylinder engine, known for its very cultivated running and spontaneous power delivery."

auto motor und sport, Germany, May 14, 2003

1 - In Europe, the new Series is offered as a 530i and a 530d, the latter with a 215-hp turbodiesel engine.



Performance & efficiency features

Under the hood and transmission tunnel of each new 5 Series model is a powertrain that, if not totally new, brings together exciting new combinations and significantly advances BMW's state of the art. There are three engines – inline 6-cylinders in two sizes for the 525i and 530i, and the amazing new Valvetronic V-8 for the 545i. Each is available with a choice of three transmissions, all 6-speeds: manual, STEPTRONIC automatic and Sequential Manual Gearbox (SMG). Each "power team" meets a specific type of customer preference; each

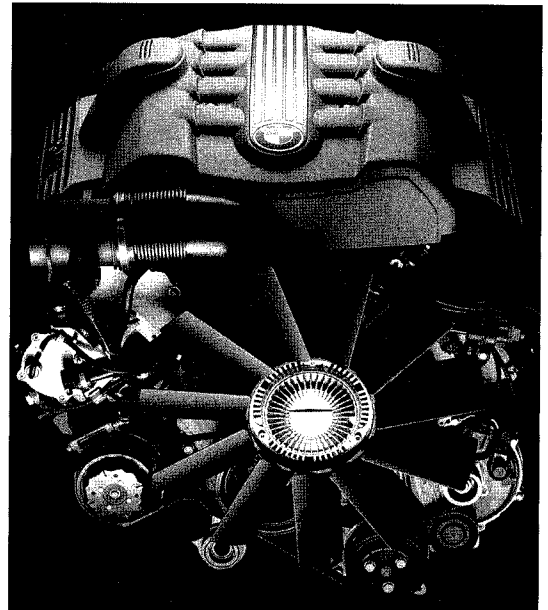

delivers typical BMW driving satisfaction in its own way. The manual and automatic transmissions are significantly improved over their predecessors; the SMG is an all-new "way to go" for the 5 Series.

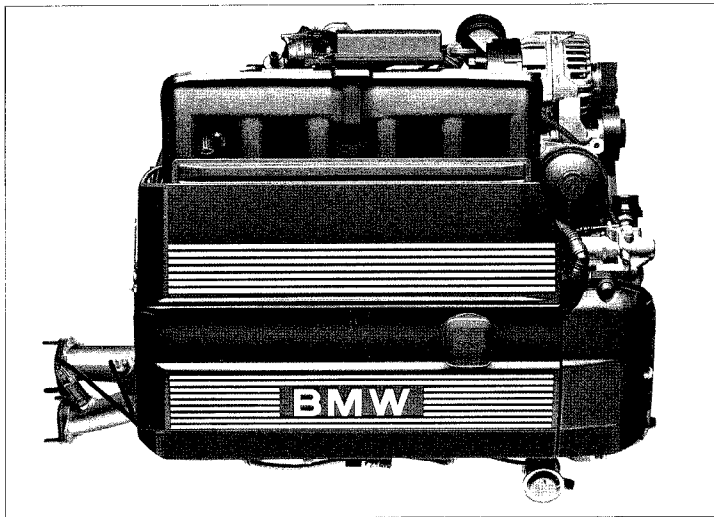

The 525i and 530i are powered by what *Car and Driver* called "magical six-cylinder powertrains that spin with velvety smooth-

ness while delivering thrust completely out of proportion to their size."

DOHC 24-valve inline 6-cylinder engines in two sizes for the 525i and 530i

Benefits

- **BMW's unique approach to 6-cylinder power**
- **Turbine-smooth operation, enhanced by the new Series' body/chassis structure and powertrain mounting system**
- **Great 6-cylinder sound, yet also quiet enough to meet expectations of luxury-oriented buyers**
- **Fuel efficiency enhanced by reduced vehicle weight, improved aerodynamics and 6-speed transmissions**
- **Lively performance – even better than that of predecessor models**
- **Both engines meet ULEV II (Ultra-Low Emissions Vehicle) emission standards**

As before, the two 6-cylinder Sedans are the 525i and 530i, powered by the familiar M54 2.5- and 3.0-liter versions of the inline 6-cylinder engines that are a BMW hallmark as well as a never-ending source of critical praise and owner satisfaction. "This example of the high art of engineering," wrote Germany's authoritative *auto motor und sport* magazine in a test of the 530i in August '01, "runs so smoothly that it makes itself heard only by a well tempered trumpeting at high rpm – there, where every one of its [225] horses⁴ tugs mightily on its bridle." In its January '02 bestowal of

the annual 10Best awards, *Car and Driver* praised BMW's "magical six-cylinder powertrains that spin with velvety smoothness while delivering thrust completely out of proportion to their size."

Though their official power and torque ratings are unchanged in the E60s, both "sixes" incorporate refinements introduced in the Z4 Series: fine-tuning of the intake and exhaust systems to enhance response at low to medium speeds. The 525i engine delivers 184 hp, 175 lb-ft. of torque and a 0-60-mph time of 7.8 sec. with the newly standard 6-speed manual transmission or Sequential Manual Gearbox, 8.2 with automatic; with its 225 hp and 214 lb-ft. of torque, the 530i achieves a 0-60-mph time of 6.6 seconds with manual transmission, 6.9 with automatic.

Both 6-cylinder engines include the following features:

- **Inline 6-cylinder configuration**, for smoothness and sound that few, if any, V-6 engines can match.
- **Aluminum construction**, contributing to performance and BMW's optimum front/rear weight distribution by holding down engine weight.
- **Dual overhead camshafts and four valves per cylinder**, for optimum torque and power.
- **Chain camshaft drive**, requiring no period replacement.
- **Double VANOS⁵** steplessly variable valve timing, enhancing torque, power and emission control.

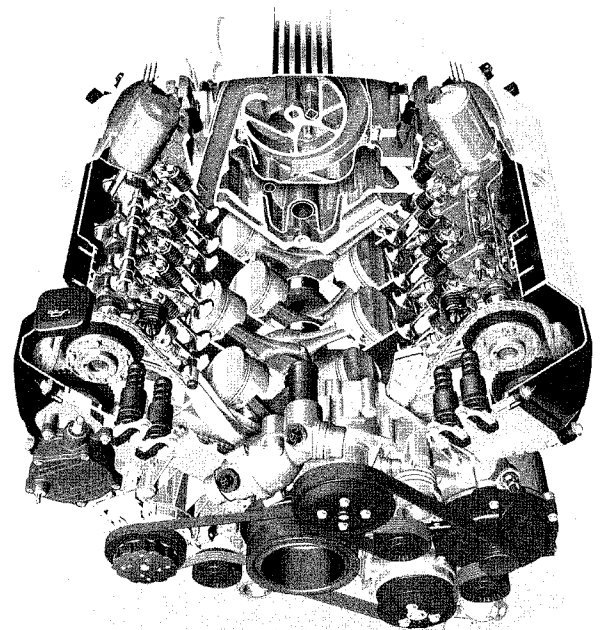

BMW advances 5 Series V-8 power with the N62 engine, seen first in the 7 Series and now powering the 545i. This ultra-advanced powerplant features Valvetronic variable

valve lift; Double VANOS variable valve timing; a fully variable intake manifold; and other innovations. At 325 hp, power is up fully 35 hp over the 540i predecessor models.

- **Hydraulic valve adjustment** for consistently quiet operation and reduced maintenance.
- **Electronic throttle system** ("drive by wire") for smooth, precisely tuned throttle action and seamless integration of cruise control, Dynamic Stability Control, Dynamic Driving Control and other features.
- **Electronically controlled engine cooling**, for precise and purposeful control of engine temperatures; contributes to fuel efficiency and heater effectiveness.
- **The latest electronic engine management**, shared with the Z4 versions of these engines (which are also available with Dynamic Driving Control).
- **Both engines meet ULEV II emission standards**. In meeting this Ultra Low Emissions Vehicle standard for vehicles sold in the U.S., BMW has achieved an advance over previous versions of these engines.

Advanced N62 DOHC 32-valve (4-cam) V-8 engine for the 545i

Benefits

- **Revolutionary and unique power concept dramatically increases performance over already strong previous V-8**
- **Exceptional response to accelerator pedal**

- **Ultra-refined operation (smoothness)**
- **Exciting V-8 sound, yet quiet enough to meet expectations of luxury-oriented buyers**
- **Fuel efficiency enhanced by new technology, reduced vehicle weight, improved aerodynamics and 6-speed transmissions**
- **Excellent cold starting**

545i is of course a new model designation, replacing the present 540i. The "uprating" comes from the V-8 model's new engine: the N62 unit that made its debut in the 7 Series in 2002.

Though the V-8's displacement, 4.4 liters, is unchanged from the previous M62 V-8, virtually everything else about it is new. Not that anyone was complaining about the present engine: "The buttery 4.4-liter V-8," raved *AutoWeek* in its August 12, 2002 issue, "gives the 540i Sport Wagon a powerful punch of power."

The new engine delivers a considerably greater "punch of power": At 325 hp, the N62 puts out a full 35 hp more than its predecessor. With the 6-speed manual transmission or SMG, official BMW data indicate a

4 - The magazine quoted 231 hp, which is the European rating; but the Euro and U.S. engines are essentially the same.

5 - VANOS = VAriable NOckenwellen Steuerung = variable camshaft control, or variable valve timing.

Performance & efficiency

0-60-mph time of just 5.7 sec.; with the automatic, it's within a fraction of a stopwatch tick at 5.8 sec.!

Equally remarkably, it can be expected to achieve higher fuel efficiency as well: Official EPA mileage ratings aren't available yet, but this new engine lifted the V-8 7 Series from 17/23 mpg ('01 740i) to 18/26 ('02 745i) despite greater vehicle weight in '02. And response to the accelerator pedal – we can no longer say “throttle” – is markedly livelier, more spontaneous. How BMW achieved all this continues to be unique and fascinating:

Valvetronic: revolutionary new “breathing” concept. Many engines now have variable valve timing, including all of BMW's. A number of manufacturers, BMW among them, achieve variable valve timing – the valves do not always open and close at the same point in the combustion cycle – by rotating the camshaft relative to its driving sprocket⁶. A few, notably Honda, vary valve timing via a mechanism with more than one cam lobe per valve; Honda (including Acura) also uses this mechanism to change valve lift – the distance the valve is opened from its seat in the combustion chamber.

Varying valve lift is a step beyond varying timing. Valvetronic varies lift – but to a far greater, and more fundamental, degree than any other system. Indeed, so extensively that it replaces the traditional engine throttle: engine breathing is controlled entirely by the valves, and the traditional throttle simply goes away.

The Valvetronic mechanism sits atop the intake valves on each of the V-8's two cylinder banks. Each of the engine's 32 valves is actuated as the camshaft lobe deflects a finger-type rocker arm. On the intake side, there is an additional element between the cam lobe and rocker arm, an intermediate follower.

Upon contact by the camshaft lobe, this intermediate follower actuates the rocker arm and, in turn, the valve. The follower is held in place by an eccentric shaft that can be rotated by a

small servo motor. This shaft, which rotates in response to the driver's accelerator-pedal movements, determines the intermediate follower's pivot point and thus varies the valve lift. The system can vary valve lift all the way from 0.3 mm to 9.7 mm.

Like many ingenious developments, Valvetronic is straightforward in principle, though someone had to think it up in the first place. BMW engine engineers thought it up; BMW has patented Valvetronic. The system's highlights:

- **Intake valves assume function of throttle.** Engine breathing – air intake – is controlled by varying this lift. The driver's foot gives the commands; valve lift varies accordingly. At minimum lift, the engine is idling or decelerating; at maximum lift, it produces full power.
- **Greater efficiency.** As a throttle closes, it imposes a restriction that incoming air must snake around. This causes so-called “pumping losses,” which take an increasing portion of engine power in lower-speed driving. By eliminating the throttle(s)⁷ and letting the valves control the breathing, Valvetronic essentially does away with pumping losses.
- **More spontaneous engine response.** Drivers are impressed by how spontaneously and quickly the engine responds to the accelerator pedal.
- **More power.** High valve lift contributes to high power output; yet in a traditional engine, one cannot simply increase valve lift, as too-high lift would degrade operation at low speeds and loads. With Valvetronic, valve lift is tailored precisely to operating conditions – and is extra-high at the top end. This helps the N62 engine achieve its amazing power.
- **Refined engine operation.** In light-load driving, operation is especially smooth because of the relatively small valve lift of 0.5 to 2 millimeters. Customers may notice the engine's ultra-smooth idling.

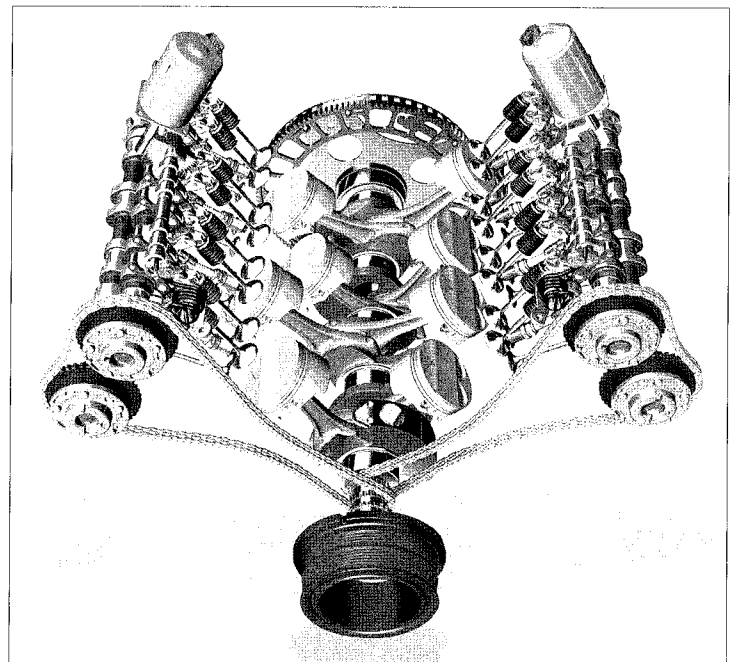

Unlike any other variable valve mechanism currently offered, Valvetronic varies intake-valve lift so widely that it replaces the conventional throttle; this sharply reduces so-called “pumping” losses, increasing the

engine's power output very significantly. In this view of the engine's valve mechanism, Valvetronic's most prominent components are the servo motors, housed in canister-like units at the top of the illustration.

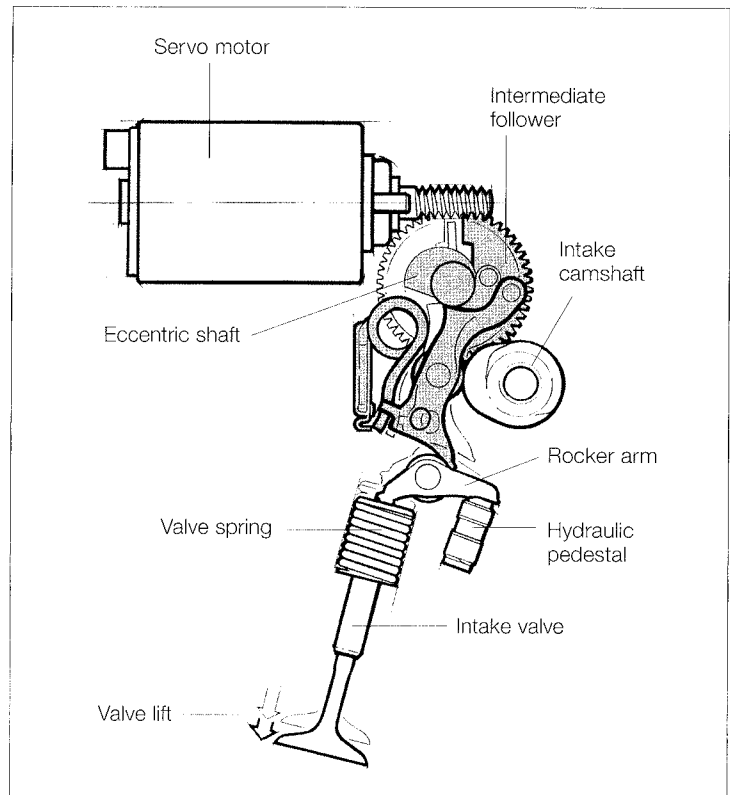

This schematic drawing of the Valvetronic mechanism shows the system's components and functions:

- Servo motor – rotates eccentric shaft to vary the position of the intermediate follower according to accelerator pedal
- Intermediate follower – varies valve lift

- Rocker arm – actuates valve
- Hydraulic pedestal – maintains valve clearance at zero for minimum noise
- Intake valve – opens to allow air and fuel into cylinder
- Valve spring – closes valve
- Valve lift – the distance the valve is opened.

- **Excellent cold starting.** The small valve opening promotes highly effective vaporization of fuel, even when the engine is being started from cold.
- **No mechanical throttle linkage.** All current BMW engines have electronically controlled throttles, so-called “drive-by-wire.” With Valvetronic, this feature is even more natural: Via the pedal, the driver’s call for power is transmitted electronically to the eccentric shaft’s electric servo motor.
- **Stepless variation of valve lift.** Valve lift is varied continuously and smoothly all the way from minimum to maximum lift.
- **Lightning-fast system response.** The system can vary lift all the way from minimum to maximum in just 300 milliseconds, or 0.3 sec. To achieve this, BMW developed a dedicated Valvetronic micro-processor, which networks with the 40-megahertz/32-bit primary engine computer.
- **Low friction, precision components.** Every “rubbing point” in the Valvetronic mechanism is not a rubbing (friction) point at all. Instead, low-friction rollers transmit the motion: from cam lobe to intermediate follower, from intermediate follower to rocker arm, from eccentric shaft to intermediate follower. The follower itself is a precision casting in the first place, machined to virtual perfection. Its “boomerang” contour – the working surface that actuates the rocker arm – is machined to a tolerance of 8/1000ths of a millimeter. To ensure quiet operation, zero valve clearance is maintained hydraulically.

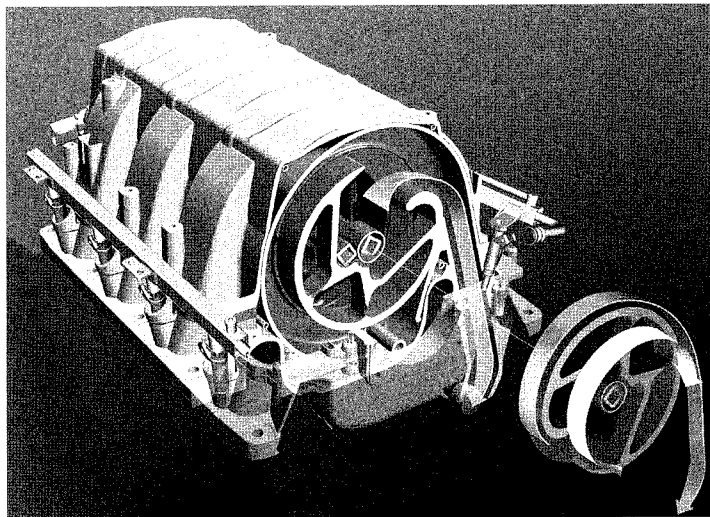

A 2-stage variable intake manifold can improve low-speed torque and high-end power. The N62 engine’s fully variable intake manifold goes a step further, providing an

optimum intake length for every operating condition. Two intertwined helical elements, rotated by an electric servo motor, make it possible to vary intake length steplessly.

Double VANOS. With introduction of this engine into the 5 Series, Double VANOS steplessly variable valve timing now appears in all BMW engines except that of the ALPINA ROADSTER V8. Responding to operating conditions and the driver’s demands for power, Double VANOS rotates the intake and exhaust camshafts steplessly between “earliest” and “latest” valve timing.

As in other engines with Double VANOS, this feature enhances the engine’s torque, fuel efficiency and emission control. Here it operates in combination with Valvetronic to help achieve heretofore unknown levels of performance, efficiency and general operational excellence.

Fully variable intake manifold: another major new technology. Some current engines, including the 525i and 530i units, employ 2-stage intake manifolds. Generally, these have a flap mechanism that switches between two paths for air entering the engine: one tuned for low- to medium-speed operation (improving torque and response), the other for high-speed operation (improving top-end power).

For the N62 engine, BMW engineers evolved this concept into a fully, steplessly variable intake manifold. The engine team conceived an internal mechanism consisting of two intertwined helical elements which, rotated by an electric servo motor, vary the effective intake length steplessly. Like Valvetronic and stepless Double VANOS, this manifold concept dispenses with traditional compromises to achieve truly optimum performance.

The proof is in the driving: media praise. All this groundbreaking technology pays off in real-world performance, as media critics have found in their tests of 745 models with this engine:

- *auto motor und sport*, Germany, November 14, 2001: “The new 4.4-liter V-8 with Valvetronic is a superior powerplant. In terms of acoustics and vibration, it moves on silky-quiet paws, reacts quickly to the accelerator pedal, and puts out strong power.”

- *Car and Driver*, January 2002: “This 325-hp Valvetronic V-8 is nothing short of magnificent. Smooth and silent at idle and cruising speeds, it sings a lovely muted tenor note on the boil. And it flat gets up and flies, the transmission handing off from one cog to the next as seamlessly as an Olympic relay runner.”

Other advanced features: liquid-cooled alternator, aluminum block. Continuing an advanced underhood feature of BMW V-8 and V-12 models, the electrical/electronics system is powered by a liquid-cooled alternator. Compared to conventional air-cooled types, the liquid-cooled alternator is more compact, produces more electrical power, and is fully encapsulated for exceptional quietness.

As before, the engine’s cylinder block is of Alusil – silicon-impregnated cast aluminum – for light weight and long-wearing durability. Silicon crystals are cast into the block; a so-called “soft honing” machine removes just enough of the aluminum to leave the crystals as the ultra-hard cylinder surfaces.

The N62 engine of U.S. models meets LEV (Low Emissions Vehicle) standards. Its engine management system, though mostly similar to that in the 745i/Li models, has been further developed to accommodate additional functions.

6 – Or, in engines with a timing belt instead of chain drive, camshaft pulley.

7 – Actually there is an auxiliary throttle, for certain specific functions only: as a fail-safe measure for the unlikely event of Valvetronic malfunction; for diagnostic purposes; to control fuel-tank ventilation; and to improve cold starting. Under virtually all normal operating conditions, this throttle is open.

**Transmissions:
three choices for each
model, all 6-speeds**

Benefits

- 6-speed transmissions across the board
- Each model offers a choice of manual, SMG or STEPTRONIC automatic
- Manual and automatic transmissions incorporate significant improvements over their predecessors
- SMG is an entirely new “way to go” for the 5 Series

All transmissions for the new 5 Series are brand-new, and every one is a 6-speed. Although not all competitors’ plans for 2004 are known at this writing, this 6-speed strategy may be an industry exclusive.

6-speed manual transmission

Benefits

- Even more precise shifting than previous transmissions
- Shorter movements from gear to gear further enhance BMW’s already legendary driving pleasure
- 6-cylinder models offer this feature for the first time
- 6 speeds improve both performance and cruising comfort

Two transmission types are offered in the range of 5 Series models, both of them new and significantly evolved from either the previous 525i/530i 5-speed or the 540i 6-speed.

525i and 530i. Previous 5 Series 6-cylinder models came standard with an excellent 5-speed manual transmission. This new 6-speed, first seen in the Z4 and now

standard in 330 models as well, enhances the performance, driving pleasure and possibly even the fuel efficiency of the new 525i and 530i models.

Weighing no more than the previous 5-speed, the ZF Type H transmission offers –

- New, even more effective synchronization of shifting
- Lighter and more pleasing feel as the shift lever is moved from gear to gear
- Sportier shift action, via 10-mm (0.4-in.) shorter shift “throws” from neutral to each gear.

Compared to the previous 5-speed, the 6-speed’s internal ratios for 1st through 5th gears are approximately the same; the major gearing difference is 6th gear, which provides a 0.85:1 ratio for a relaxed cruising feel and satisfying fuel efficiency.

545i. The new 5 Series V-8 model is again among the few 8-cylinder automobiles available with a 6-speed manual transmission. A new 6-speed makes its first appearance here. It shares all the operational advances of the Type H, is lighter than the 6-speed it replaces, and has specific gear ratios to harmonize with the V-8 engine. (Final drive ratios are specific to each model; see **technical specifications**, page 56.)

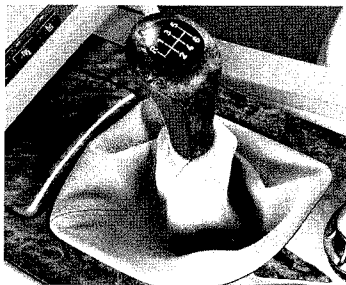

Every E60 5 Series model comes standard with a 6-speed transmission. This is the manual 6-speed, which is produced in two types: Type H for the 6-cylinder engines, Type G for the V-8.

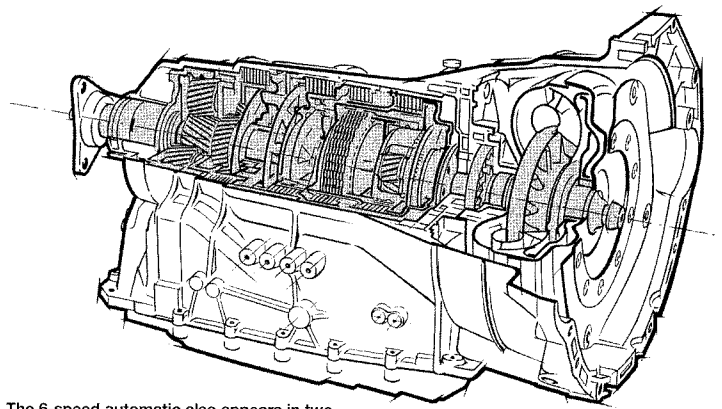
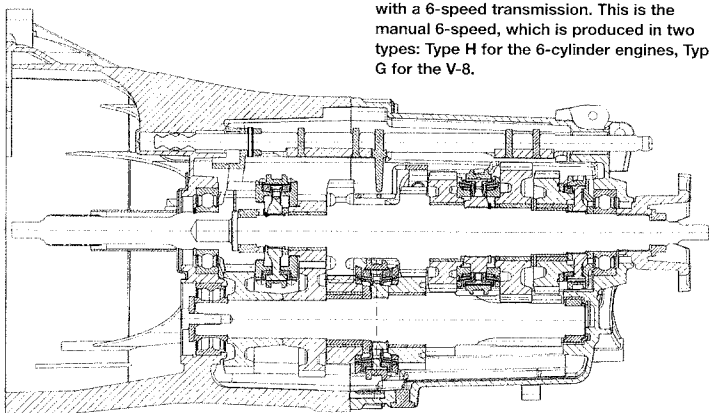

The 6-speed automatic also appears in two types: 6 HP 19 for the 6-cylinder models, making its first appearance; and the 6 HP 26 for the V-8, first seen in the 7 Series. They are conceptually identical but sized to match the two engine types. Switzerland’s *Automobil Revue* reported that “the ZF automatic shifts silky-smoothly and virtually imperceptibly.”

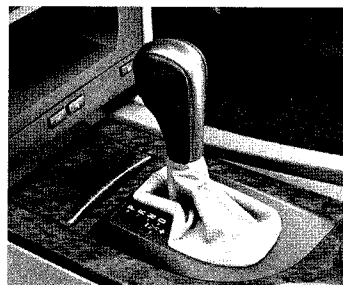

- **Mechanical shift lever.** The 5 Series has a mechanical shift lever on the console, with the familiar P-R-N-D ranges on the right, the M/S gate on the left, and up- and down-shifting by tipping the lever rearward and forward.

Otherwise, this is the same unit that plays a role in the 745 models’ outstanding powertrain performance, with the six speeds complementing the Valvetronic engine’s wide rpm range, facilitating a virtually seamless flow of power, and providing a highly relaxed 6th gear for cruising at Interstate and freeway speeds.

6-speed STEPTRONIC automatic transmission

Benefits

- Additional gear over previous 5-speed unit makes for an almost “seamless” flow of power from a standstill to the highest cruising speeds
- 6th speed is an even more relaxed cruising gear
- Reduces fuel consumption
- Actually lighter than previous 5-speed automatics
- Even smoother than predecessor automatic

Brand-new is a 6-speed automatic for the 6-cylinder models too: the **ZF 6 HP 19**. Derived from the 6 HP 26 and providing the same gear ratios, this unit is sized for smaller engines; compared to the 5-speed unit it replaces, it’s fully 10% lighter, has a more efficient torque converter, actually operates with fewer internal clutches than the 5-speed, and can reduce overall fuel consumption by up to 4%.

With the E65 7 Series, BMW introduced the first 6-speed automatic transmission in a production car®, the ZF 6 HP 26. The 545i, with the same engine as that in the 745i/Li, offers this same transmission, with two essential differences from the 745 version:

- **STEPTRONIC** is standard from the start on all E60 automatic transmissions; in fact, as of the ‘04 model year, all BMW automatic transmissions are STEPTRONIC.

On the 525i and 530i, the automatic transmission is an option. Like its 540i predecessor, the 545i comes in two versions: with automatic transmission and “normal” equipment, or with manual transmission and standard Sport equipment. Also as with the 540i, customers who want Sport equipment and the automatic transmission can specify the automatic-transmission model with Sport Package.

6-speed Sequential Manual Gearbox (SMG): new option for the 5 Series

Benefits

- Brings Formula 1 racing technology to the road
- First appearance in a BMW Sedan for the U.S. market
- Retains efficiency and performance of manual transmission, yet offers choice of automated or manual shifting
- Includes Dynamic Driving Control (Sport button)
- Can shift faster than even an expert driver
- No clutch pedal
- Manual shifting via shift lever or steering-wheel "paddles"

Yet another new 5 Series feature. To be offered in the 530i and 545i as of 9/03 production and 525i as of 3/04 production (only in combination with Sport Package), the E60's SMG is similar to that offered in the Z4 Series, rather than the BMW M version with Drivelogic.

Like all BMW SMG versions, this is an electrohydraulically shifted, electronically controlled rendition of a 6-speed manual transmission, including an automatic clutch; as such it is an utterly different type of transmission from a conventional automatic such as the STEPTRONIC unit. There is no clutch pedal; the driver selects the desired mode (N, R, D, M) with a console-mounted selector lever, and can execute manual shifts via that lever or two "paddles" on the steering wheel. The fundamental advantages of SMG are that it fully preserves the performance of a manual transmission, entails little or no penalty in fuel economy, and facilitates both automated and very sporty driving.

Features and characteristics of the SMG driver interface include the following:

- A **Drive** mode (D) in which shifting is automated⁹
- A **Manual** mode (M) in which shifting is mostly driver-controlled
- A **Sport button** on the console, which selects a Sport program

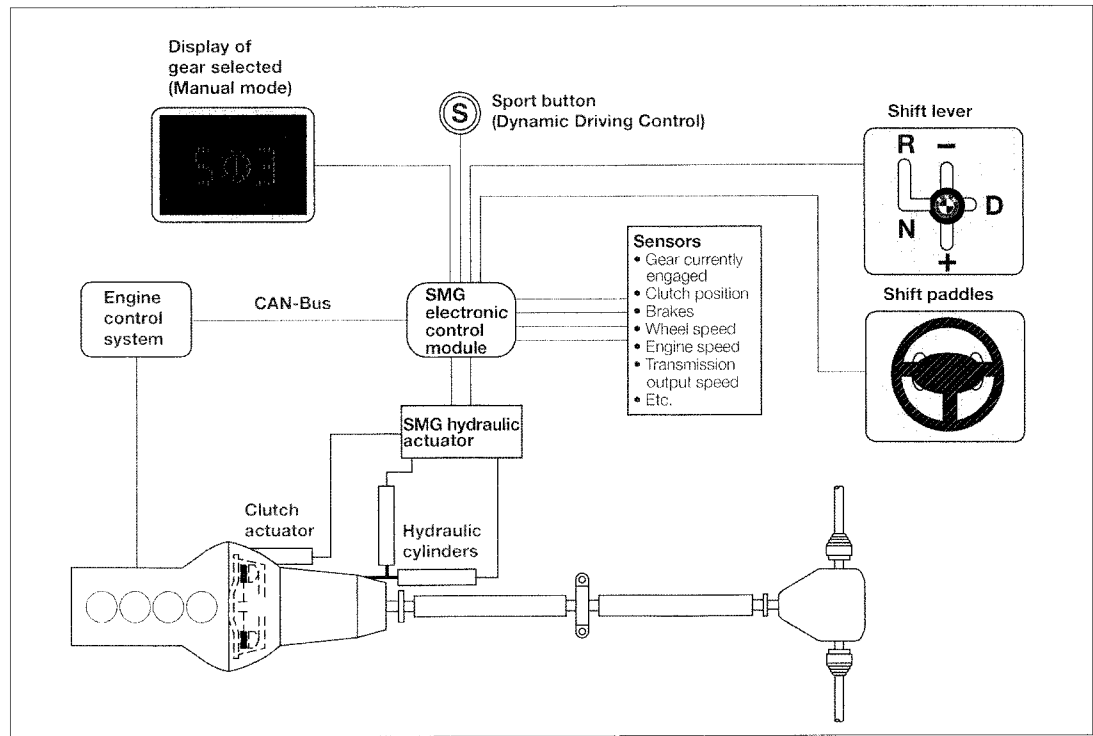

BMW's 6-speed Sequential Manual Gearbox is offered on all E60 models in combination with the Sport Package. Its shift control system offers Drive (automated) and Manual modes, plus a Sport mode.

- An **instrument-panel display** of the gear currently engaged and the operational range currently selected.

In D, shifts are automatic, and programmed according to how the driver is currently driving: More aggressive driving results in shift points at higher speeds. As with the M3 SMG's A mode⁸, D is not to be interpreted as a substitute for the D of a fully automatic transmission, but rather a convenient operational mode for those times when the driver wants ease of driving and is not primarily concerned with extracting maximum performance.

With M selected, the driver essentially determines all shifting by means of the shift lever or paddles –

- Tip lever or paddle(s) rearward = upshift
 - Tip lever or paddle(s) forward = downshift
- with the following exceptions:
- If the driver takes the engine up to its rpm limit, SMG will automatically shift to the next higher gear.

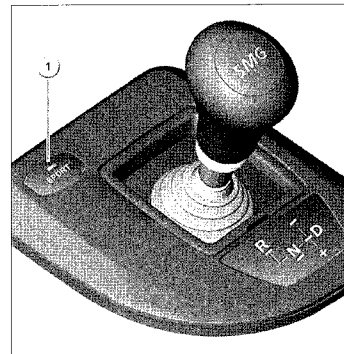

The SMG Sport mode is activated by pressing the Sport button (1) on the console.



Shift "paddles" on the steering wheel: thanks to Active Steering, now more convenient.

- Upon deceleration, as the engine comes down to approximately 1100 rpm, SMG selects the next lower gear. When the vehicle comes to a stop, SMG selects 1st gear automatically; upon moving off, however, the driver again controls the shifting.

Engaging the Sport program via the Sport button on the console influences shifting as follows:

- In manual shifting, shifts occur more quickly (sharply).
- In D, shifts occur not only more quickly, but at higher road speeds. This is parallel to the Sport mode of BMW automatic transmissions.

In the Sport program, throttle action is also "quicker"; that is, a given amount of movement at the accelerator pedal produces more throttle opening.

An instrument-cluster display tells the driver which of the six speeds is currently engaged. In D, it also shows a "D."

⁸ – Some CVT (Continuously Variable Transmissions), such as Audi's Multitronic and the MINI automatic, offer six "artificial" ratios from the transmission's infinite number of ratios. BMW's 6-speed is a true 6-speed. Since the 7 Series' debut, other vehicle models have introduced 6-speed automatics.

⁹ – As of 9/03 production, D (Drive) and N (Neutral) will replace A (Automated) and O (Neutral) in all BMW SMG transmissions, including that of M3s.

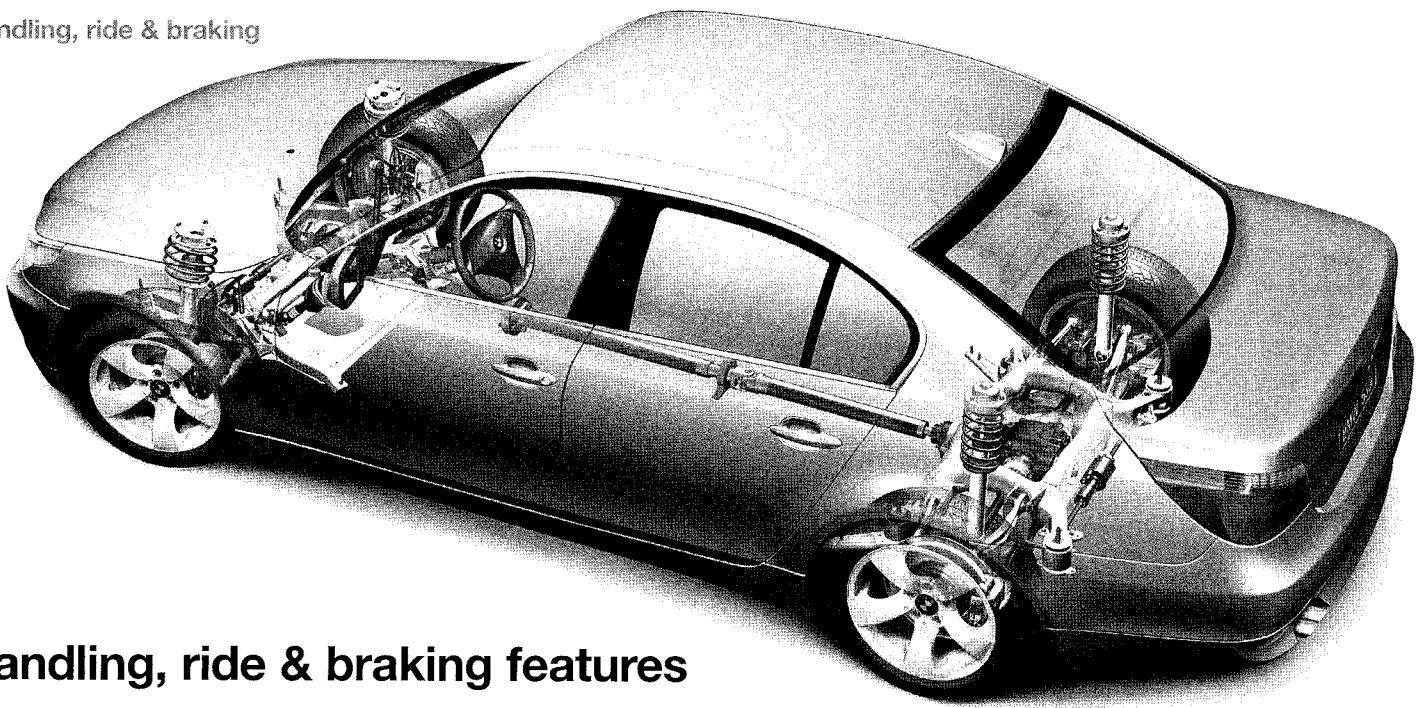

Handling, ride & braking features

Over its 7-year production cycle, the E39 chassis has been considered by most of the motoring media as one of the “wonders of the world.” With its rigid body structure, advanced suspension design and the fine-tuning at which BMW is absolutely the best, it has delivered a combination of handling prowess and supple comfort that competitors could only aim at, but never attain.

The new E60 5 Series evolves this illustrious standing further; competi-

tors will once again find themselves scrambling to keep up. As always with new BMW vehicle generations, the chassis/body unit’s structural rigidity has been further improved – from a predecessor that was already exemplary in this respect.

The fundamental chassis engineering – the front and rear suspension systems – is essentially similar to that of the 7 Series, which in turn is an evolution of the previous 5 Series.

Front suspension and steering system: full aluminum, rack and pinion now on all models

Benefits

- **Aluminum suspension system delivers an amazing combination of handling ability and riding comfort on all types of road surfaces**
- **V-8 models now have the added precision and light weight of rack-and-pinion steering, with no loss in luxury feel**

The front suspension system is evolved from the E39 6-cylinder system, which means it is a virtually full aluminum system teamed with rack-and-pinion steering. (V-8 E39s' front end had a steel subframe and recirculating-ball steering.) The system's geometry continues to be of the double-pivot type, a unique BMW system that has

proven benefits in handling stability and response. All E60 5 Series models, thus not just the 6-cylinder ones, now also benefit from the reduced unsprung weight that optimizes the suspension's response to irregular road surfaces. In less technical terms, this simply means that when a wheel encounters a bump, it offers less resistance and inertia and thus deals with that bump more willingly. In turn, this allows the suspension engineers to achieve a supple ride in combination with precise, responsive and enjoyable handling.

Aluminum components include (those marked with an asterisk are newly in aluminum for the V-8 model):

Unsprung –

- Both lower arms (two per side)
- Steering knuckles
- Strut tubes

Sprung –

- Spring pads
- Subframe*
- Thrust plate (actually a new component, similar to that found in M3s and Z4s)
- Steering rack*.

Other aluminum components in this area, though not part of the suspension system, further contribute to overall weight savings: engine mounting brackets, transmission cross-member and mounting brackets, power-steering pump housing.

The adoption of rack-and-pinion steering for all 5 Series, not just the 6-cylinder models as in the E39 platform, follows its appearance on the 7 Series a year ago and marks a transition that BMW has carefully developed. In the past, the more luxurious BMWs have used recirculating-ball steering, which transmitted less road shock to the steering wheel

but was heavier and somewhat less precise near the straight-ahead position. As of the E60 debut, all BMW models now have rack-and-pinion steering.

In the meantime, BMW has developed rack-and-pinion steering to the point where it delivers traditional rack-and-pinion advantages (lightness, greater precision) while also minimizing the transmission of road shocks. The 5 Series' rack-and-pinion system also has the special feature of a variable ratio (not to be confused with variable assist, which all BMW power-steering systems have). The rack's teeth are profiled to make the steering ratio become quicker (that is, more steering effect for a given steering-wheel motion) as the wheel is turned outward from the center position. The result is a fine-tuning of steering response according to the situation one is in, be it on a fast straightaway or maneuvering into a parking space.

Active Steering: dramatic advance in vehicle dynamics

Benefits

- **An amazing advance in steering capabilities and driving feel**
- **A BMW exclusive**
- **Included in all Sport Packages**

This hotly rumored innovation, exclusive to the 5 Series, is included in the Sport Package for each model. It expands dramatically on the variable-ratio principle, as explained under **options & accessories** on pages 42-44.

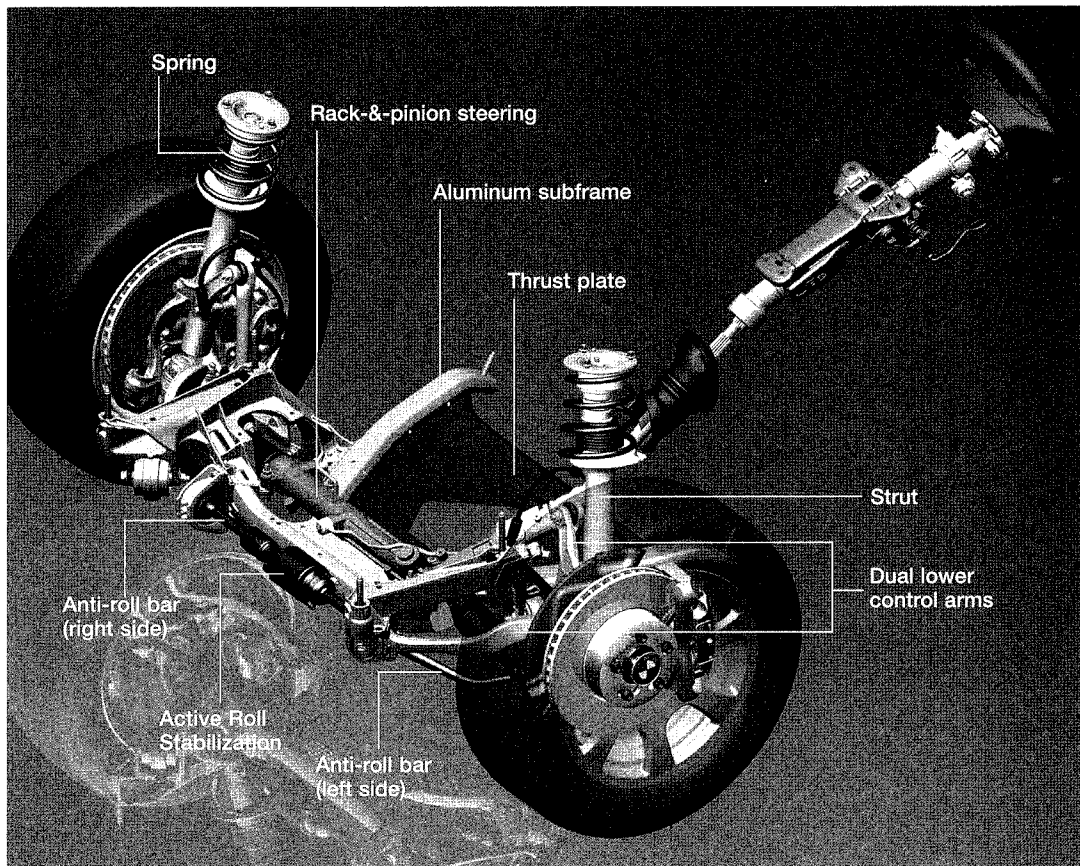

The new 5 Series' front suspension is evolved from that of the previous Series; now all models have the weight-saving aluminum front subframe and rack-and-pinion steering formerly reserved for the 6-cylinders. An

aluminum thrust plate, a concept first seen on M3s, adds rigidity in the area where the suspension system attaches to the underbody, enhancing precise handling without adding excess weight.

Rear suspension system: careful evolution

Benefits

- **Precise control of rear-wheel angles for sporty, yet stable handling**
- **As with front suspension, aluminum components enable suspension to deliver a supple ride over all road surfaces**

The 7 and 5 Series as well as the Z8/ALPINA ROADSTER V8 have a very sophisticated multi-link rear suspension layout called the Integral system.

Highly refined rear suspension is particularly important in high-performance rear-wheel-drive vehicles; a complex multi-link system like this controls rear-wheel angles very precisely, minimizing unwanted effects under load changes (such as lifting off the gas while cornering, and hard acceleration or braking) and achieves a remarkably comfortable ride.

Here, in a continuation of existing 5 Series practice and sharing componentry with the current 7 Series, aluminum is again extensively employed. Because supple reaction of the suspension to bumps is especially critical for good road adhesion at the powered rear wheels, the benefits are if anything more important here than at the front. Aluminum components include:

Sprung –

- Subframe
- Spring pads

Unsprung –

- All links of the 4-link Integral system
- Shock-absorber tubes.

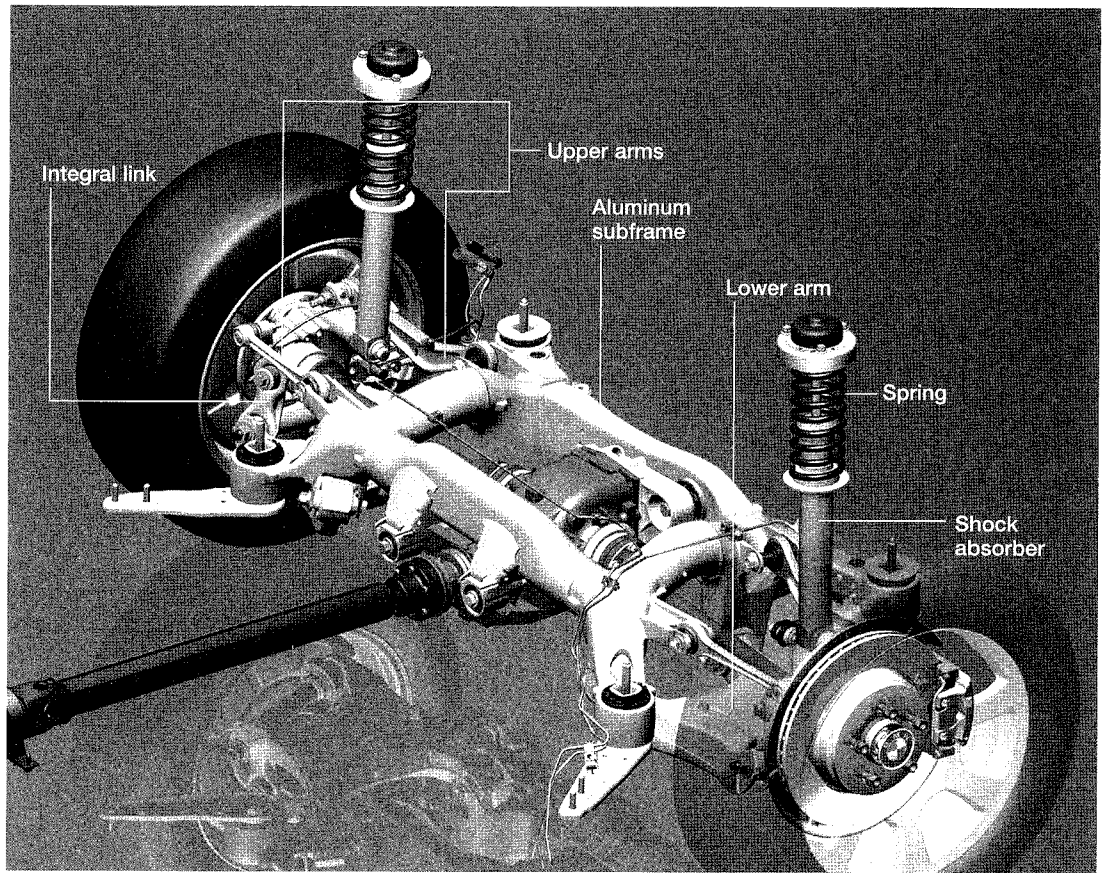

Most major moving parts of the Integral rear suspension, as well as the subframe, are made of weight-saving aluminum.

The aluminum subframe, which carries the entire rear suspension system and final drive (differential), is mounted to the main structure with four large rubber bushings which help absorb road shocks.

The final drive unit is mounted to the subframe through its own rubber bushings. Thus with two stages of vibration and noise absorption between it and the body, the differential is **acoustically decoupled** from the body, minimizing any gear noise inside the car.

Conventional anti-roll bars standard, ARS optional

Benefits

- **Standard-equipped models continue and refine BMW's legendary suspension tuning for handling and comfort**
- **Sport Package-equipped models achieve the amazingly "flat" cornering ability of Active Roll Stabilization (ARS)**

In standard form, all E60 models have conventional anti-roll (stabilizer) bars. The Active Roll Stabilization (ARS) that is standard on the 7 Series comes to the E60 5 Series as part of the Sport Package; see **options & accessories** for details on this fascinating concept, which makes for amazingly "flat" cornering.

Ventilated disc brakes: more stopping power, new weight-saving technology

Benefits

- True to BMW tradition, braking performance and technology have again been advanced
- 545i models introduce compound (iron/aluminum) construction for a further reduction in unsprung weight and smoother operation in hard braking

Compared to those of the predecessor Series, the brakes of each new 5 Series model are upsized for even greater braking performance:

- **525i** – 310-mm diameter x 24-mm thickness front brakes, vs. previous 296 x 22 (12.2 x 0.94 in. vs. previous 11.7 x 0.87); 320 x 20-mm rear brakes, vs. previous 298 x 20 (12.6 x 0.79 in. vs. previous 11.7 x 0.79).
- **530i** – 324 x 30-mm front brakes (12.8 x 1.18-in.) are unchanged; 320 x 20 rear brakes, vs. previous 298 x 20 (12.6 x 0.79 in. vs. previous 11.7 x 0.79).
- **545i** – 348 x 30-mm front brakes vs. previous 540i's 324 x 30 (13.7 x 1.18 in. vs. previous 12.8 x 1.18 in.); 345 x 24-mm rear brakes vs. previous 540i's 298 x 20 (13.6 x 0.94 in. vs. previous 11.7 x 0.79 in.).

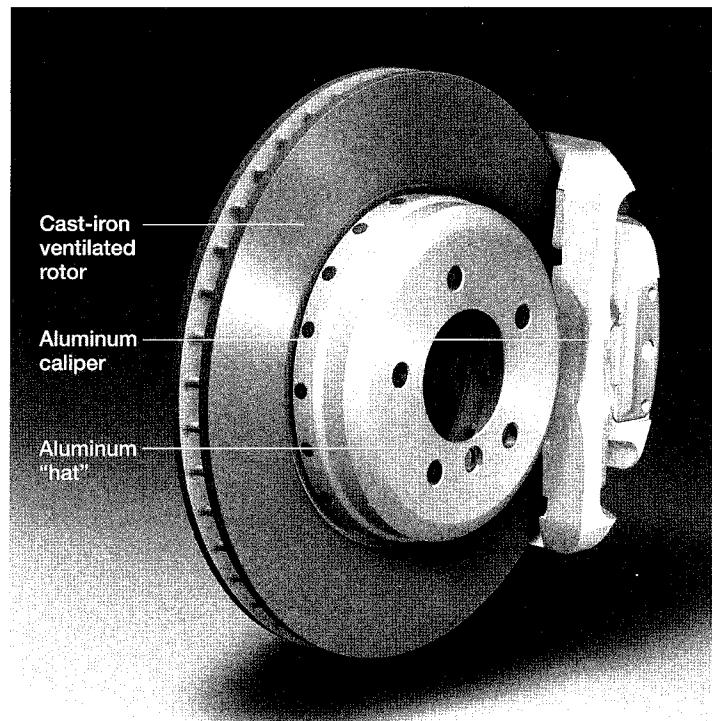

New 2-piece aluminum/cast-iron construction of 545i brake rotors (discs) introduces a further reduction of unsprung weight; it also reduces rotor deformation under high heat, making the brakes operate more smoothly in extreme use.

All discs are ventilated. On the 6-cylinder models, their cast-iron rotor construction has been optimized for a modest weight reduction. On the 545i, an innovative, new, weight-saving construction is introduced for the first time on a regular-production BMW. (European M3 and M5 models use similarly constructed brakes.)

In this construction, referred to as **compound brakes** and **patented by BMW**, the brake rotor (disc) consists of two pieces: the high-carbon cast-iron outer portion, which functions conventionally as the surface onto which

the brake pads grip to slow or stop the vehicle; and an aluminum "hat" in the center, which mounts the rotor to the vehicle. The concept's advantages include:

- **Reduced unsprung weight**, complementing the aluminum suspension components described earlier. Actual weight reductions are approximately 1 kg (2.2 lb.) at the front, 0.7 kg (1.5 lb.) at the rear – very significant in the scheme of things.
- **Reduced deformation of the rotor** under hard braking, by approximately 20%. In practical terms, this means less tendency of the brakes to vibrate when hot, and reduced likelihood of the rotors cracking under extreme heat conditions.

All brake calipers are of aluminum, which also reduce unsprung weight. This is an advance over the previous 5 Series, in which the 6-cylinder models had aluminum calipers all around but 540i models had cast-iron front calipers. Thus with the new 5 Series, BMW has acted to maintain or extend its lead in reducing unsprung weight – a lead that the predecessor Series opened in 1997, and which helped that 5 Series set new standards in combining top handling with amazing riding comfort.

Self-adjusting handbrake mechanism

Benefits

- Reduces need for adjustment
- Ensures that braking force is always equal on both rear wheels

Two refinements to the handbrake mechanism nicely illustrate BMW's attention to details that affect usability and maintenance requirements. One is that the handbrake actuating cable is now self-adjusting, so that adjustment is required less frequently. The other is that the cable mechanism is newly designed to ensure that braking force – which can become unequal between the two rear wheels to which it is applied as wear occurs – is always equal. This innovation was first seen in the Z4.

Wheels and tires: upgraded all around, two choices for each model

Benefits

- **Six distinctive wheel/tire combinations, tailored to each standard and Sport Package-equipped model for optimum road capabilities and visual identification**
- **Standard 525i's lightweight forged wheels complement the aluminum suspension system, further reducing unsprung weight in this most weight-conscious model**
- **Model for model, all wheel/tire equipment upgraded from previous 5 Series**

Model	Equipment	Wheel size & design	Tires	Upgrade over E39 5 Series
525i	Standard	16 x 7.0 Trapezoid #134, (lightweight forged alloy)	225/55R-16 V-rated all-season	Wheels: lightweight forged alloy vs. cast Tires: V-rated vs. H
	Sport Package	17 x 8.0 Star Spoke #122	245/45R-17 W-rated run-flat performance	Tires: run-flat, 245/45 vs. 235/45
530i	Standard	17 x 7.5 Star Spoke #138	225/50R-17 V-rated all-season	Wheels & tires: 17-in. vs. 16 Tires: V-rated vs. H
	Sport Package	18 x 8.0 Star Spoke #123	245/40R-18 W-rated run-flat performance	Wheels & tires: 18-in. vs. 17 Tires: run-flat, 245/40 vs. 235/45
545i	Standard	17 x 7.5 Double Spoke #116	225/50R-17 V-rated all-season	Wheels & tires: 17-in. vs. 16 Tires: V-rated vs. H
	Sport Package and 6-Speed model	18 x 8.0 front/18 x 9.0 rear Star Spoke #124	245/40R-18 front / 275/35R-18 rear W-rated run-flat performance	Tires: run-flat Rear tires: 275/35 vs. 265/35

Each model offers a choice of wheel-and-tire equipment: standard and Sport Package. All wheel designs are new, and run-flat tires make their first 5 Series appearance as part of all Sport Packages. Every wheel/tire combination represents an upgrade over current 5 Series equipment, as shown in the table at above right.

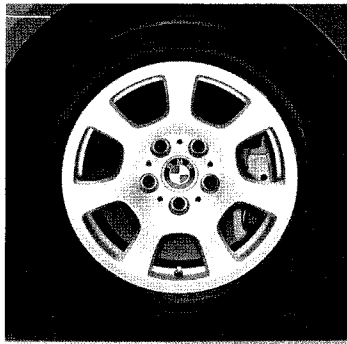

Premium wheel technology for base 525i: In addition to the aluminum suspension, lightweight forged-alloy wheels further reduce unsprung weight. Sized 16 x 7.0, these wheels are in a Trapezoid design (#134) and carry 225/55R-16 V-rated all-season tires.

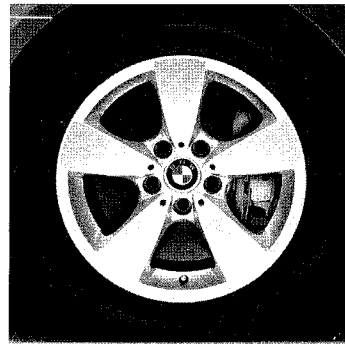

Standard 17 x 7.5 wheels are an upgrade in 530i standard equipment over the previous model's 16 x 7.0 size. They carry 225/50R-17 V-rated all-season tires (vs. the previous H-rating) and are in this Star Spoke design (#138), with five tapered spokes that reach all the way out to the rim.

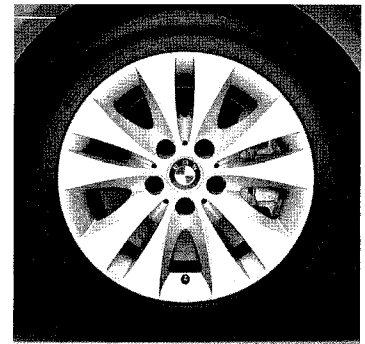

The 545i's standard wheels are in a bold Double Spoke design (#116); they are upgraded like those of the 530i to 17 x 7.5 dimensions, and also wear new 225/50R-17 V-rated all-season tires. Like the standard 530i wheels and all Sport Package wheels, these also have spokes that extend out to the rim.

Run-flat tires with all Sport Packages

Benefits

- **In combination with special wheel design, run-flat tires allow driving for up to 90 miles on flat tire**
- **Run-flat tires are especially suitable for sporty vehicles because of their very firm sidewalls**

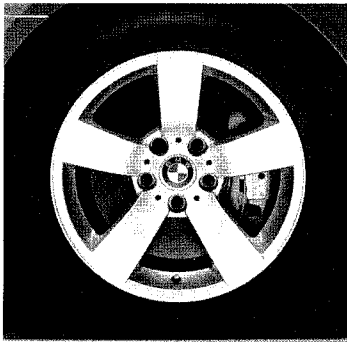

The 525i Sport Package includes 17 x 8.0 Star Spoke wheels, design #122, carrying 245/45R-17 W-rated run-flat performance tires. The wheels' five spokes, which extend right out to the rim, leave plenty of open space for brake ventilation and a view of the aluminum brake calipers.

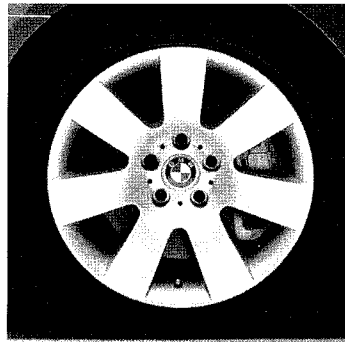

Another Star Spoke design, the elegant 7-spoke #123, comes with the 530i Sport Package in a hefty 18 x 8.0 size ('03 530i: 17 x 8.0). 245/40R-18 W-rated run-flat performance tires connect these wheels with the road with abundant grip.

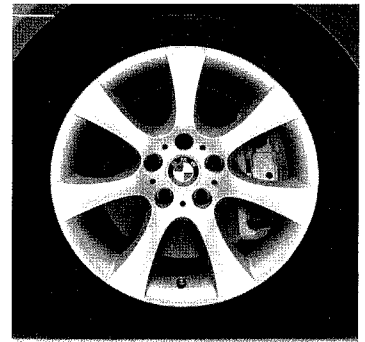

The sportiest E60 wheel-and-tire equipment is this very open Star Spoke design (#124), sized 18 x 8.0 front/18 x 9.0 rear and carrying 245/40R-18 / 275/35R-18 W-rated run-flat performance tires.

Every Sport Package-equipped '04 5 Series model (including the 545i 6-Speed with its standard Sport equipment) comes with BMW's run-flat system, which consists of self-supporting tires and wheel rims that are specially shaped to help keep a flat tire securely in place. All these tires are performance-oriented W-rated rubber.

In their design and configuration, the self-supporting tires are distinguished primarily by their special sidewalls, which include specific inserts and highly heat-resistant rubber compounds. These features allow a deflated tire to maintain its essential shape and guidance characteristics for

a considerable distance, so that when confronted with a flat the driver can continue on until reaching a convenient and safe place to have the tire repaired or replaced.

While maintaining essentially the handling and safety standards expected of high-performance tires, the run-flat system offers the following advantages:

No roadside tire changes. The driver does not have to stop and change a damaged tire. Even with no air in the tire – a condition

revealed to the driver by the standard Flat Tire Monitor – one can continue driving at 50 mph for up to about 90 miles.

Tire stays on rim, thanks to specially developed Extended Hump wheel rims.

Stability systems remain functional. All Dynamic Stability Control functions remain fully functional, even with a deflated tire.

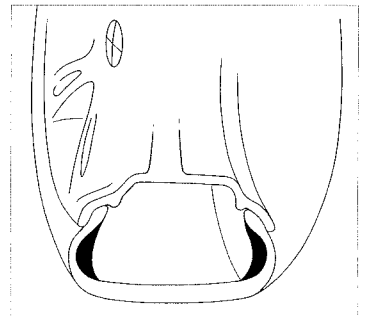

All new 5 Series models come standard with run-flat performance tires. The reinforced, self-supporting tire sidewalls and special rim configuration designed to keep a flat tire securely on the rim are shown here.

Standard Flat Tire Monitor on all models

Benefit

- Alerts driver to loss of air pressure in any tire
- Because loss of tire pressure can adversely affect handling, enhances driving safety with standard tires
- Because the change in handling is less pronounced when run-flat tires lose pressure, the monitor may be the driver's only immediate indication of pressure loss

All new 5 Series models are standard-equipped with the **Flat Tire Monitor**. Whenever tire pressure drops by 30% or more, the tire's rolling radius changes significantly; this means the wheel will rotate at a different speed from the other tires on the vehicle. FTM measures wheel rotation via the DSC wheel-speed sensors, and recognizes any major deviation in wheel speed (and therefore tire pressure). Within a short time, the system triggers a pressure-loss signal via an indicator in the instrument cluster and an audible warning.

In contrast to the previous 5 Series, all the new models come standard with a space-saver spare wheel/tire unit, which contributes to the increased trunk space and allows space for some electronic componentry in the spare's compartment under the trunk floor.

Riding comfort: on the same high level

Benefits

- Advancing a quality that helped make the predecessor Series such an amazing vehicle
- Demonstrating that outstanding handling doesn't have to be gained at the expense of riding comfort and quietness

Given the outstanding riding comfort of the previous 5 Series – acclaimed the world over as remarkable given its also out-



standing handling – it was the goal of BMW's engineers to achieve the same high level of comfort in the new Series, even with various weight savings throughout the vehicle. This is by no means a simple task: When developing an essentially all-new vehicle, acoustics engineers must essentially start all over again, exploring every possibility of noise and vibration inside the vehicle, analyzing these in computer simulations, conducting extensive vehicle tests, defining and quantifying those disturbances that are observed in early prototypes, and developing solutions to them. The new aluminum front end posed particular challenges – not because it is inferior to a steel structure in terms of noise, but because it is different and had to be addressed anew.

BMW's Research and Engineering Center and the BMW Proving Ground provide the resources to conduct all this work, in the form of "anechoic chambers" where vehicle noise can be measured in total isolation from extraneous and ambient noise; BMW's Acoustic Wind Tunnel, where aerodynamic noise can be evaluated; and other facilities – all of which allow the engineers to conduct their work with the vehicle operating (on dynamometer rollers) just as if it were on the road.

In driving the new 5 Series models, critics and customers alike will find that BMW's goals have been attained, and that these new vehicles are at least as comfortable to drive and to ride in as their illustrious predecessors – while retaining the sporty sound characteristics that always make BMWs not merely quiet and comfortable, but also actively pleasant to experience.

Dynamic Stability Control in its latest form

Benefits

- Full-function, state-of-the-art traction and stability system
- Enhances the 5 Series' inherently dazzling road capabilities
- Includes Dynamic Traction Control

DSC appears in its latest form (version 8.0) in the new 5 Series. Thus it incorporates various programming refinements and the Dynamic Traction Control function that first appeared in the 7 Series and is now included in the 3 and Z4 Series as well. Activated (as in the 3 and Z4) by pressing the DSC console switch

The previous 5 Series set new standards for combining outstanding handling with a supple, comfortable ride. Its successor advances these standards once again.

briefly, DTC improves utilization of available road traction under specific conditions –

- on sand, gravel, deep snow or packed snow
- climbing hills with deep or packed snow
- when there is deep snow on only one side of the road
- when driving with tire chains.

With DTC selected, engine intervention is de-activated at low speeds, leaving only the individual wheel brakes to control wheelspin. When the vehicle reaches a speed of approximately 43 mph, normal DSC operation is re-instated until speed once again drops below this threshold, at which point DTC operation resumes. A longer push of the DSC button de-activates all DSC functions except antilock braking.



Exterior & aerodynamics features

Look at those lines: tightly dimensioned, short overhangs, lean-forward dynamics, compact overall. That's 5 Series tradition – the unique combination of sedan practicality and BMW sportiness that has characterized this Series through all its generations. The “design language,” on the other hand, is totally new. Though not merely a resized version of either, the new 5 is clearly consistent with BMW's other recent new designs, the 7 Series and the Z4 Series.

New styling is by no means all the new 5's body is about; it also incorporates fascinating and meaningful new technology. The entire front end – structure and skin – is made of aluminum to reduce overall vehicle weight and to further optimize front/rear weight distribution. At the rear, Adaptive brakelights help make following drivers aware when the BMW driver is braking hard. And these all-new sport sedans are BMW's most aerodynamic ever.



In front view, the new 5 preserves the “crouching” aspect that gave its predecessor such a look of road competence, while being new in every detail. It is shown here with Xenon Adaptive headlights.



At the rear, the new 5 evolves the trunklid concept initiated by the 7 Series with a high lid for increased cargo capacity; the lid integrates gracefully with the body’s side lines.

The look: aesthetics and function

Benefits

- **BMW’s design strategy for today and tomorrow maintains BMW identity while giving each Series highly distinctive character and advanced styling**
- **The E60 5 Series design rests on twin pillars of tradition and future**
- **Typical 5 Series proportions and overall size**
- **Tastefully restrained use of trim**
- **A look of strength and dynamics**
- **Incorporates many functional innovations**

Starting at the front: The “kidney” grilles, a strong link to BMW tradition, are up-front and prominent, surrounded by painted surfaces and flanked by “quad” headlights (with BMW’s popular luminous rings) under break-resistant clear covers. The body sides are ultra-clean, deriving their esthetic interest not from lots of lines and trim, but from a complex interplay of concave and convex surfaces best perceived in strong light that elicits brightness and shadows (as seen clearly in the photo on the facing page).

The door-handle design – curved handles that are pulled outward after reaching into a recess behind them – is shared with the

3 Series and similar to that of the 7 Series. Side windows are framed in matte black, with a discreet chrome accent in the familiar BMW manner; with Sport Package the chrome is omitted and this trim is called Shadowline as usual. The fuel door is of the “push-push” type recently introduced in other Series.

Deeply wrapped-around lighting units at the front and rear not only add visual interest, but perform their functional duties (turn signals, side markers) admirably. The turn signals have clear (“white”) lenses front and rear; the front parking lights are a thin, wedge-shaped “eyebrow” of amber LEDs that lures admirers. Window areas are generous and incorporate the traditional BMW “reverse kink” in the rear door window, while allowing for the beefy roof pillars that contribute to customers’ expectations of excellent accident protection.

At the rear, the E60 expresses BMW’s new trunklid concept – featuring a high lid for increased cargo capacity – with an elegant and flowing integration into the silhouette and attractive, highly functional taillight wraparounds.

Modest dimensional growth all around lends greater substance to what was already one of the midsize luxury class’s most substantial concepts. With its 2.3-in. longer wheelbase and 2.6-in. greater overall length, the new 5 enhances riding comfort and interior accommodations

without becoming a truly “big” car. Body width is up by 1.8 in., height by 1.5 in. The accent on measurable benefits is in the rear seats and trunk.

Adaptive brakelights: a functional innovation

Benefits

- **Add illumination area and brightness when BMW driver brakes hard**
- **Help alert following drivers and avoid rear-end collisions**

Adaptive brakelights made their world debut on the 7 Series; in the meantime they’ve appeared on the Z4 and (most recently) 3 Series Coupes and Convertibles. They are standard on the new 5 Series too, employing light clusters whose active area increases under hard braking.

There are two taillight segments per side, whose function is frequently monitored by the Check Control system. Under normal braking, these same two segments illuminate more brightly. Under heavy braking or anytime the ABS goes into action, round segments at the inboard side of each taillight unit illuminate to enlarge the total brakelight area. Following drivers are thus alerted automatically to sharp braking by the BMW driver, lessening the likelihood of a rear-ender.

The visible 5 Series – what the onlooker sees – subtly communicates the lean, strong structure that underlies its athletic shape.

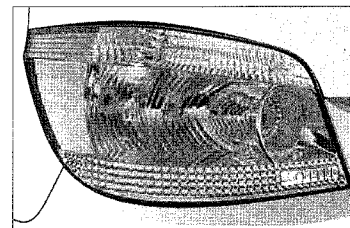

Adaptive brakelights, so far exclusive to BMW, employ LED clusters whose active illumination area increases under hard braking.

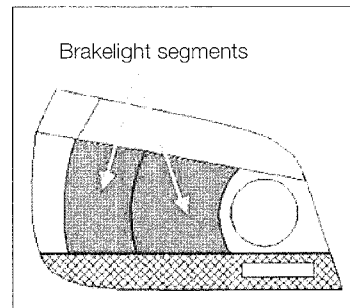

Under normal braking, the large area of LEDs shown here illuminates.

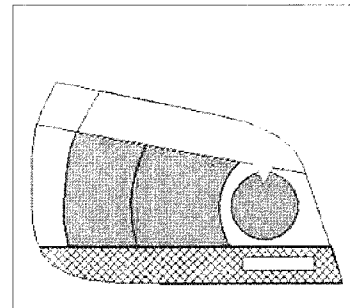

Under hard or emergency braking, an additional, circular area (bulb here, not LEDs) illuminates brightly to give following drivers a clear indication that the BMW driver is slowing abruptly.

Technology of the new look: stronger and lighter structure, smoother aerodynamics

Benefits

- **Actual model-for-model weight reductions for most models**
- **Optimized weight distribution via aluminum frontal structure and skin**
- **Occupant protection is further optimized**

If "stronger and lighter" seems paradoxical, chalk the paradox up to progressive technology.

By employing aluminum for the entire front end – structure as well as skin – BMW's body engineers have pared approximately 44 pounds off the body/chassis shell's weight while simultaneously improving its strength and occupant protection. This is the most extensive use ever of structure-and-skin aluminum in a

regular-production BMW. The 7 Series has aluminum hood and front fenders, but its internal front-end structure is steel; the Z8/ALPINA ROADSTER V8 is all-aluminum but built in very small quantities.

Occupant protection (passive safety) is on a level with the 7 Series, improving upon a predecessor that gained international recognition for its outstanding safety performance.

Aluminum and steel in the new 5 Series

Benefits

- **New technology combines the two materials in an optimum way**
- **High strength and excellent corrosion resistance**

Building the Z8 and aluminum body components for other current models has given BMW great experience with this weight-saving, effectively energy-absorbing material. Bringing

structural steel and aluminum structural components together on the new 5 posed new challenges, especially with regard to maintaining the high level of corrosion resistance of today's BMWs. Vintage cars on which steel was directly adjacent to aluminum, such as the Austin-Healey of the 1950s and 1960s, suffered corrosion due to galvanic action between the two metals at these junctions. According to the materials being joined, three types of joints are employed on the 5 Series:

- Aluminum-aluminum: high-tech adhesives, rivets, laser welding
- Aluminum-steel: high-tech adhesives, rivets
- Spot welding, gas welding.

As is customary at BMW, nearly all steel panels are galvanized. Aluminum components receive a titanium/zircon coating that hinders oxidation and ensures clean, smooth surfaces for bonding with adhesives.

Once fully constructed, the body structure is dipped in a phosphate bath and then in a cathodic primer. Even in such immersion this primer cannot reach every last nook and cranny of the structure, so all contact points between aluminum and steel are bonded together in such a way that the adhesive fully covers the joint and, indeed, protrudes at least 1 mm outside the joint. Thus direct contact between the aluminum and steel is completely avoided and any chance of corrosion arising from the new construction eliminated.

Other weight-reducing techniques flowed into the E60's body engineering. All four wheelwells incorporate textile inserts that eliminate the need for separate sound insulation, saving about 35% on weight in this area. The underbody has become not only smoother (for aerodynamics) but some 40% lighter, thanks to a new protective cladding material called Superlite.

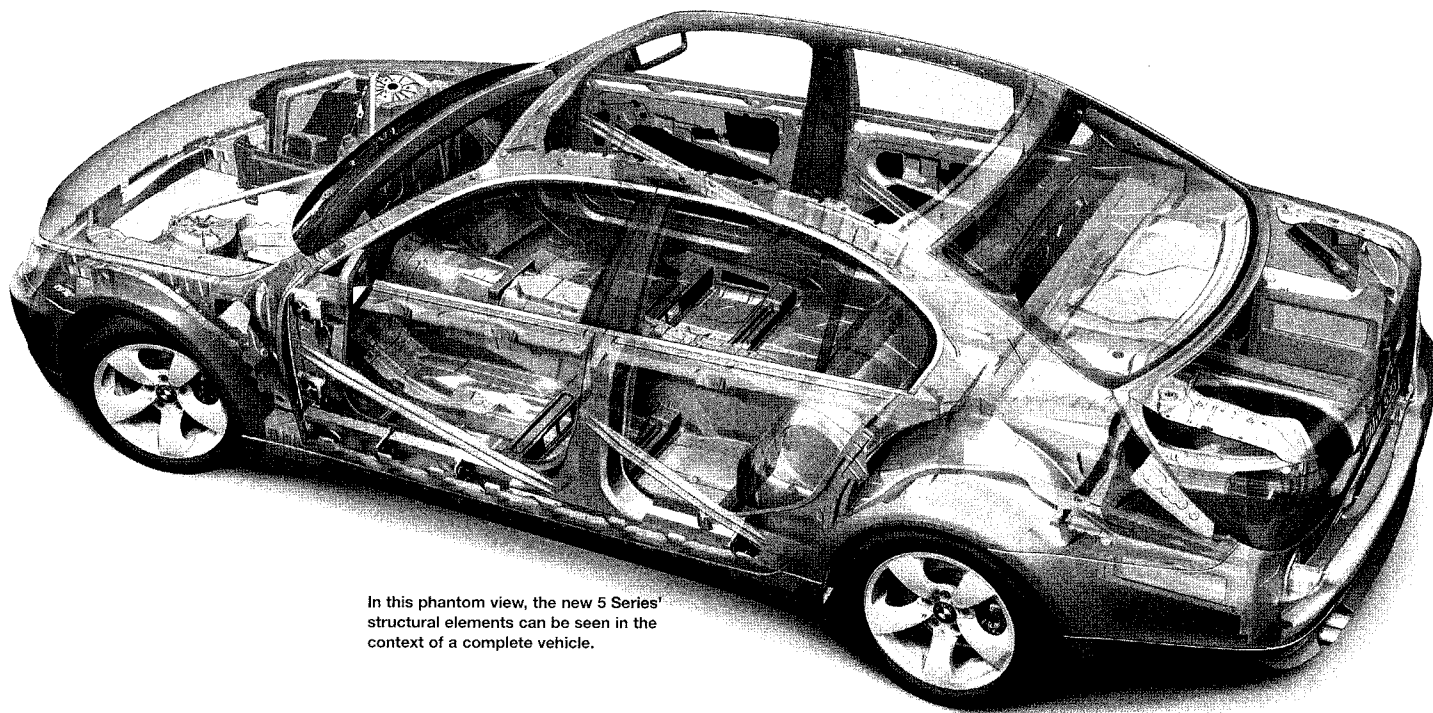

In this phantom view, the new 5 Series' structural elements can be seen in the context of a complete vehicle.

As mentioned earlier, the body/chassis shell is approximately 44 lb. lighter than before. In some cases the actual model-for-model vehicle-weight savings over '03 models come out modest; in others they are quite significant:

- 525i manual transmission -28 lb.
- 525i automatic transmission -55 lb.
- 530i manual transmission -72 lb.
- 530i automatic transmission -45 lb.
- 545i manual transmission +55 lb (weight increase)
- 545i automatic transmission -7 lb.

(SMG models weigh the same as their automatic equivalents; SMG was not available in '03 for comparison.)

If some of these decreases (and the 545i's increase) seem puzzlingly small, consider these factors:

- The new bodies are more rigid; their occupant protection has been further developed.
- The new models have more extensive standard equipment, including –
 - Larger wheels on most models (the 525i, with its lightweight forged wheels, is the exception)
 - Rain-sensing windshield wipers (the rain sensor adds a little weight)
 - Adaptive brakelights
 - Dual center console compartments with climate-controlled lower compartment

- Full dual-zone climate control (previous models offered separate left/right temperature control; the new 5 has separate left/right control of temperature and air distribution)
- Standard audio system includes two subwoofers
- More comprehensive front/rear Head Protection System.

With the new 5, BMW has stopped what seemed like an inexorable upward creep in vehicle weights. And weight reduction is a worthy goal, as long as it is not achieved by weakening the vehicle. Clearly this is the case with this new BMW Series.

Aerodynamics, too, evolve in the right direction

Benefits

- **Reduced aerodynamic drag favorably influences fuel efficiency, primarily at higher speeds**
- **Wind noise in the cabin is also potentially reduced**

Sedans of the previous 5 Series have aerodynamic drag coefficients (C_d) of 0.29-0.31 depending upon model; all '04 5 Series Sedans come in at 0.29, the greatest improvement being for the 545i vs. its 540i predecessor.

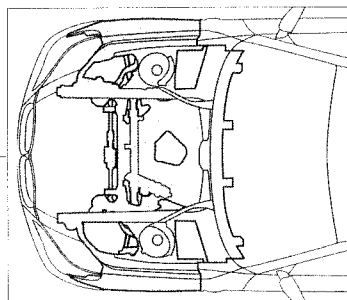
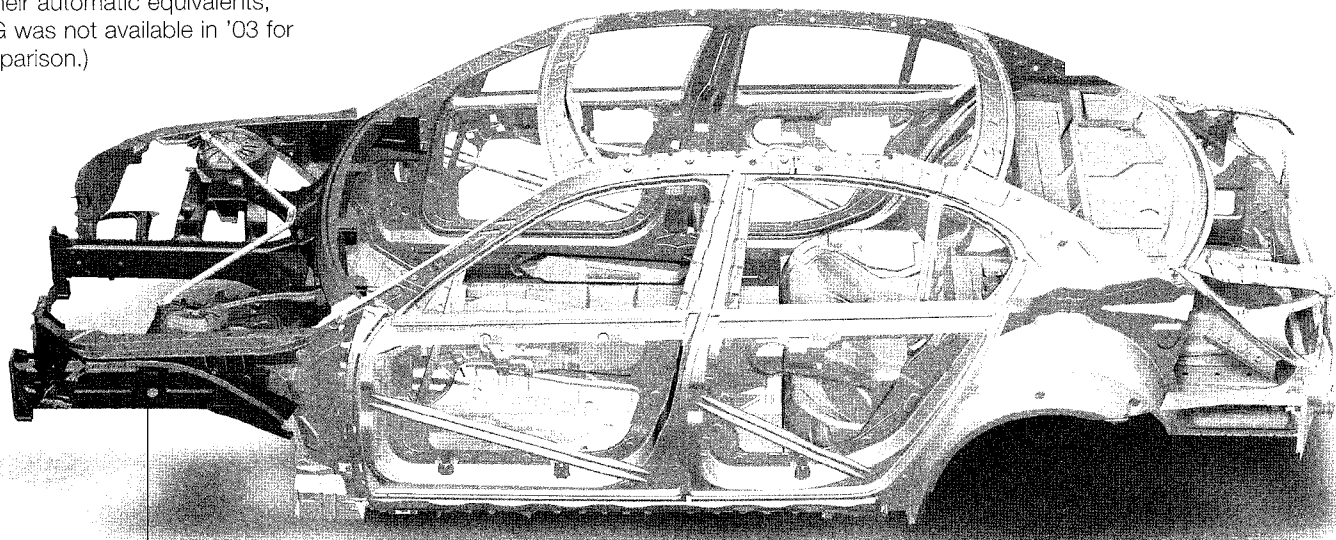

By employing aluminum for the entire front end – structure as well as skin – BMW's body engineers have substantially reduced body/chassis weight while simultaneously improving strength and occupant protection.



Ergonomics, luxury & convenience features

As explained in the Concept section, an important aspect of this virtually all-new 5 Series is greater interior and trunk space, achieved by a modest increase in overall vehicle size:

- Front seat – 0.5 in. more shoulder room and 0.3 in. more head room.
- Rear seat – 1.3 in. more shoulder room, 0.7 in. more head room and 1.8 in. more leg room.
- Trunk volume – fully 26% more according to official EPA measurement standards.

But greater space for people and cargo is only one aspect of the new 5 Series interior. The design of this cabin is just as fresh as the new exterior, and as always with a new BMW Series there is a wealth of new, thoughtful ideas to make the going even more comfortable, more pleasant, more esthetically satisfying.

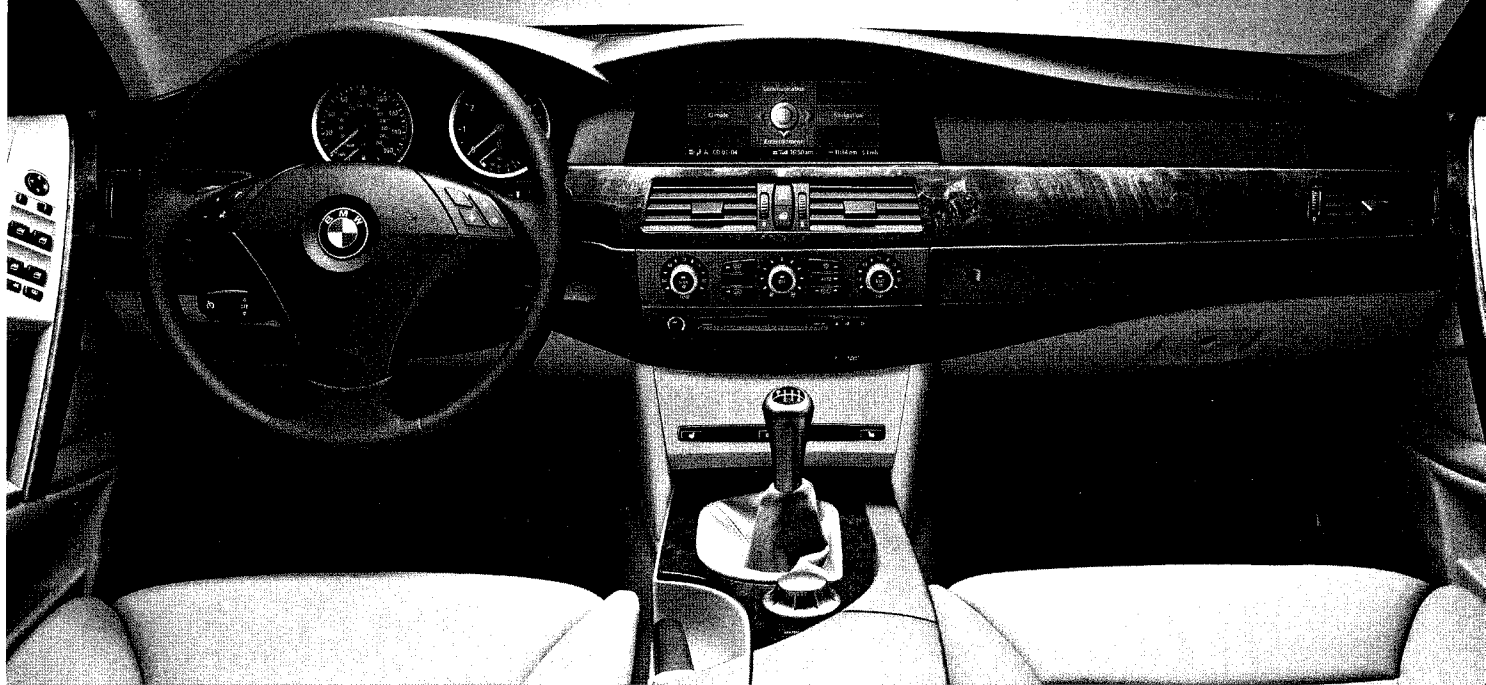

Cockpit design: flowing lines, tasteful color schemes

Benefits

- Incorporates new iDrive concept and traditional BMW elements
- Harmonious and tasteful execution of colors and trim
- New cupholder design and placement

In the design of the instrument panel and front seating, a kinship to the 7 Series is unmistakable; yet this is a wholly new design.

Unlike the 7's cluster, the two main dials include a fulltime analog fuel gauge (in the speedometer) and the traditional Energy Control fuel-economy indicator (in the tachometer). The greatest similarities to the 7 are found in the center dash area, which is dominated by the iDrive display at the top, ventilation outlets and "hard" climate controls below that, and basic audio controls farther down (the Comfort zone).

In its overall shape, the dash is dominated by a "double wave" theme that's divided into two portions: one over the instrument cluster, defining the driver's area; and another that begins over the Comfort zone (dash center) and sweeps toward the right side. There are three "color zones" here:

- Zone 1 – the dash top in double-wave form plus the surfaces just below, facing the occupants and framing the instrument cluster and iDrive monitor. Always in Basalt Gray or Black, depending upon interior color scheme.
- Zone 2 – the next level downward, again reaching from left to right, framing the steering column and climate/audio control panel. This zone also includes the trim material (Color-keyed finish or a choice of two woods).
- Zone 3 – the dash bottom, in the chosen color and including the glove compartment on the right side.

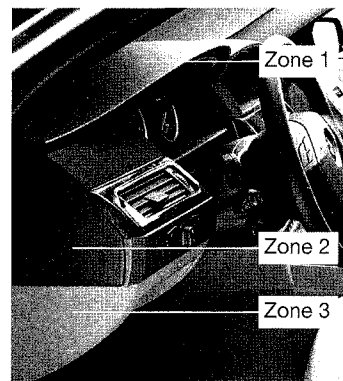

Dash contours are dominated by a "double wave" theme, one wave overlapping the other. Three color zones contribute to visual interest and color coordination with the rest of the cabin.



New, sturdier front cupholders are both positioned to right of center; driver's cupholder swings out to left for convenient access. This is the one for the passenger.

The new 5 Series interior presents fresh, elegant design, excellent ergonomics and many thoughtful convenience features to its driver and passengers.

The asymmetrically shaped center console compartment is large. Both front cupholders are positioned to the right of the center console, with the driver's cupholder swinging out to the left when opened. The front door panels pick up the color scheme and carry it rearward with a very attractive, sweeping design that's highlighted by large door pulls trimmed in metal-finish Titanium II material. The 5 Series does not have the stepless door checks of the 7 Series; it continues with BMW's more widely used, and quite satisfactory, 3-position checks for the front doors, 2-position for the rear doors.

**Control strategy:
an overview**

Benefits

- **Maintains clear differentiation from 7 Series**
- **Incorporates traditional BMW driver-oriented layout and control concepts**

Although the E60 cockpit does feature a monitor at dash center and a controller between the front seats, it does not come standard with an iDrive system as extensive as that in the 7 Series. Key differences between the new 5 and the 7 Series with regard to controls and locking include –

- **Conventional keys.** In place of the 7's "keyless" remote, the 5 retains conventional keys, the remote being integrated into the keyhead as with other BMW Series. The ignition switch is on the right side of the steering column.
- **Key starting** and engine switch-off, vs. the 7's Start/Stop button.
- **A simplified version of iDrive**, plus a more extensive version when the vehicle is equipped with the (optional) On-board Navigation System.
- **Console shift lever**, controlling the choice of manual, automatic and SMG transmissions described earlier.
- **Power-seat controls** on the seats' outboard edges. The 5 Series does not share the "menu" and "motion" scheme of the 7 Series, nor the positioning of the controls on the center console. (Nor is a Comfort rear seat, with controls also on its center console, available in the 5 Series.)
- **Traditional pull-up handbrake** instead of the 7's electro-mechanical device with control button on the dash.

- **The visual driver orientation** mentioned earlier, contrasting to the 7's strictly equal orientation toward driver and passenger. This is further emphasized by the handbrake.

The steering-column control stalks are as in the 7 Series, with electric instead of mechanical action. That is, the driver "tips" the stalk in the desired direction (for example, to activate the turn signals or to select a windshield-wiper setting) and then the stalk returns to its neutral position. Specific to the 5 Series is the placement of two push-push controls on the turn-signal stalk, one for On-board Computer functions, the other for Check Control functions. (Depending on how the vehicle is equipped, there can be up to 185 functions that Check Control monitors.)

The instrument cluster

Benefits

- **Blends traditional BMW instrument layout with fresh new visuals**
- **Includes variable tachometer warning segment**

The 5's instrument cluster is more "conventional" than that of the 7 Series, in that it doesn't use the dial faces for as many indicator lights. (Cruise-control indicators are in the speedometer face, except for the Active Cruise Control "vehicle ahead" indicator, which is between the two dials.) A feature first seen in the M5, then the M3 and most recently the 7 Series also appears here: a variable tachometer warning segment. A yellow band extends downward to 4200 rpm when the engine is cold, then gradually increases the rpm limit to normal as the engine warms up. There is no coolant-temperature gauge, but of course there is a warning indicator to indicate overheating should it occur.

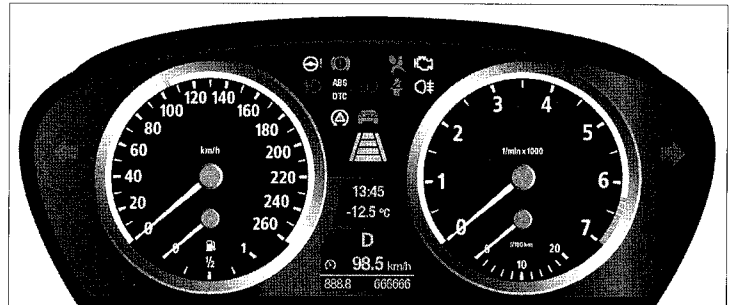

Elements of the 5 Series control strategy:
Top – Console shift lever (manual transmission shown) with controller and Menu button.
Middle – Instrument cluster, with warning and indicator lights between the main dials at top; time and temperature display below them (these displays can be pre-empted by urgent Check Control warnings); and bottom window with transmission and cruise-control displays plus odometers.

Just above – Center dash area encompasses the iDrive monitor, adjustable air outlets, hard climate and audio controls (other climate and audio functions via iDrive). In standard-equipped models, a Car Data menu point appears instead of the Navigation point shown here.

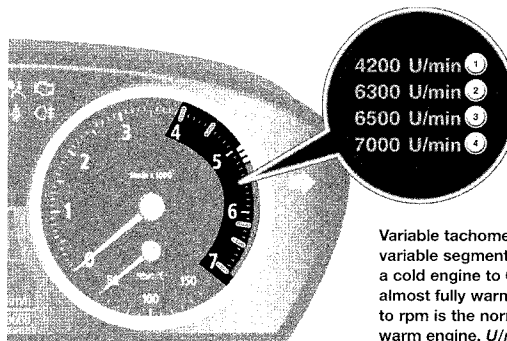

Variable tachometer warning segment: the variable segment reaches from 4200 rpm for a cold engine to 6300 rpm when the engine is almost fully warmed up. The range from 6500 to rpm is the normal red zone for a fully warm engine. U/min is German for rpm.

3-spoke steering wheel standard in all models

Benefits

- Fresh, sporty appearance with 3 spokes
- Accommodates available heated steering wheel

All models will come standard with a 3-spoke steering wheel (previously 4-spoke standard, 3-spoke sport wheel) of BMW's usual 385-mm/15.2-in. diameter. The multi-function controls – including a programmable switch – are conveniently arrayed on the wide horizontal spokes, whose lower edges and the sides of the lower spoke are attractively trimmed in the same metal-finish trim as the door pulls. As in the current 5 Series, the wheel is tilt/telescopically power-adjustable over a range of 42 mm/1.7 in. tilt and 40 mm/1.6 in. telescopic; as in the 7 Series, the mechanism is faster than in the current 5 Series. Also as currently, when the ignition key is removed, the wheel rises to its highest position (automatic tilt-up) for ease of exit and entry.

Unlike previous 3-spoke wheels, the new one is available with the optional heated rim; the control for this is on the steering column's left side.

iDrive comes to the 5 Series

Benefits

- As in 7 Series, offers many functions within a clean, uncluttered dash design
- Evolved functions, controls and graphics

Base equipment in all U.S. models is a simplified version of the iDrive setup, with a 6.5-in. color monitor (256 colors, 400 x 240 pixels). Its controller provides four menu directions, vs. the 7 Series' eight: Communication, Navigation, Entertainment and Climate, where "Navigation" does not necessarily mean the (optional) GPS Navigation system. Displays and control functions have been further refined and optimized. In rotary motion, the base-equipment controller does not incorporate force feedback, but rather a "clicking" feel to give the user a firm sense of rotation. Positioned just behind the controller is a new Menu button, which when



For the first time in the 5 Series, a 3-spoke steering wheel is standard in all models. Once again it is tilt/telescopically power-adjustable (now with faster adjustment), and when the key is removed the wheel rises to its highest position for ease of exit and entry.

pressed recalls the main menu. A fifth menu, not indicated on the main menu, is reached by pressing the controller; it allows users to choose settings and even turn off the monitor. Displayed across the bottom of the monitor are continuous indications of –

- Automatic climate control activated
- Audio source currently selected
- TMC (Traffic Message Channel) activated (if available)
- SMS (Short Message Service) message waiting (if available)
- Phone signal strength (if BMW Cellular Phone System installed)
- Time of day.

The **base version's** main-menu choices include:

Communication. This screen offers two submenus:

- 1 – phone functions, SMS, BMW Assist, notepad
- 2 – reached via BMW Assist – BMW Info, traffic info (where available), BMW Service, Emergency.

Car Data, offering four submenus: Onboard Information, Trip Computer, (speed) Limit and Stopwatch. The Trip Computer here offers more extensive functions than those previously standard in 6-cylinder models.

Entertainment. Two submenus (* indicates optional feature)

- 1 – AM/FM, Satellite radio*, CD, multimedia*, auxiliary input. Once AM or FM is selected, user can click on SET and then set tone controls, balance, fader, vehicle-speed loudness compensation, Logic 7 spatial effect* and Digital Sound Processing*.

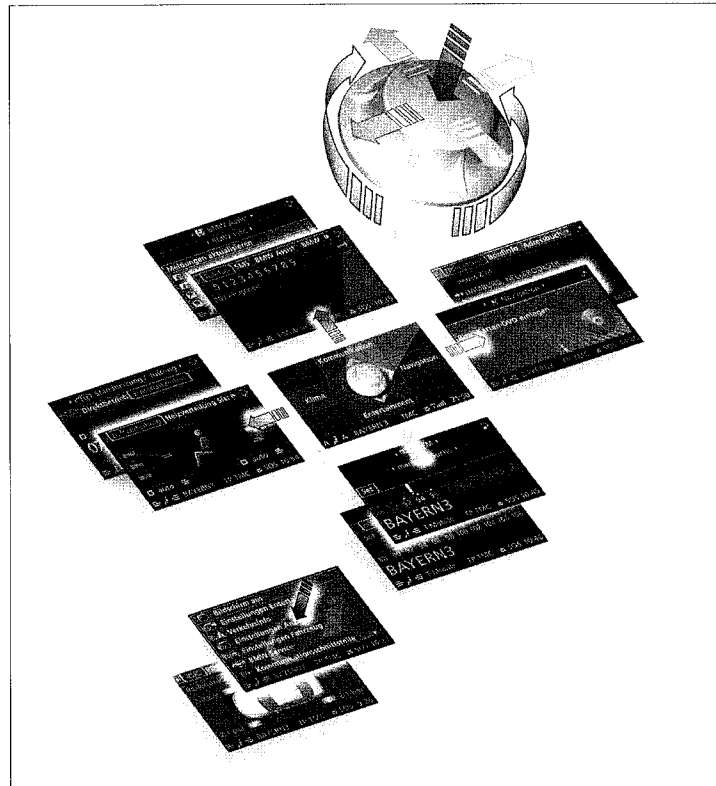

A sample of the extensive iDrive screens is shown here (in their German versions). Optional GPS Navigation screens are seen at right.

- 2 – manual tuning, search all stations, autostore, search stored stations.

Climate. Functions beyond those provided in the dash hard controls can be controlled within submenu:

- 1 – air distribution, front-seat heat balance*, automatic ventilation*
- 2 – reached via automatic ventilation – manual operation or automatic start time (runs 30 min. from start time); two start times can be set.

Settings. This is the menu that is reached by pressing downward on the controller. It offers the following range of functions:

- Monitor on/off
- Basic Entertainment settings
- Traffic Info settings
- Display settings (units of measure such as °C/F)
- Vehicle settings (selectable function for steering-wheel control, initialize Flat Tire Monitor, Daytime Running Lamps, selective vehicle unlocking and others)

- BMW Service – user can check upcoming service requirements within the Condition Based Service system (brake pads front/rear, Inspection, etc.)
- Communications connections
- Central address book.

The **Navigation version** adds or substitutes the following:

- **Larger monitor,** 8.5 in./640 x 240 pixels
- **Help screen**
- **Controller with force feedback**
- **Voice Command system.** Instead of the single Menu button behind the controller, there are two buttons: Menu and one to activate Voice Command.
- **Active Navigation menus –**
 - **GPS Navigation.** Within GPS Navigation operation, the controller has four additional (diagonal) directions of movement.
 - **"High" Trip Computer** with functions including fuel economy, speed limit, stopwatch, etc.

The DVD player that carries the Navigation System database is in the center console, below the audio hard controls; in other models up to now, it has always been in the trunk or cargo area.

Evolved automatic climate control

Benefits

- Adds left/right control of air distribution, new humidity control and climate-controlled storage compartment
- Even stronger heating and air-conditioning performance than before
- New bi-directional solar sensor enhances temperature control
- More defroster outlets

All U.S. models will come standard with the “high” automatic climate-control system, which achieves even stronger heating and air-conditioning performance than its predecessor. The system includes the following features (new features compared to the previous system are indicated with an asterisk):

- Separate left and right temperature controls
- Automatic air distribution, differentiated left/right*

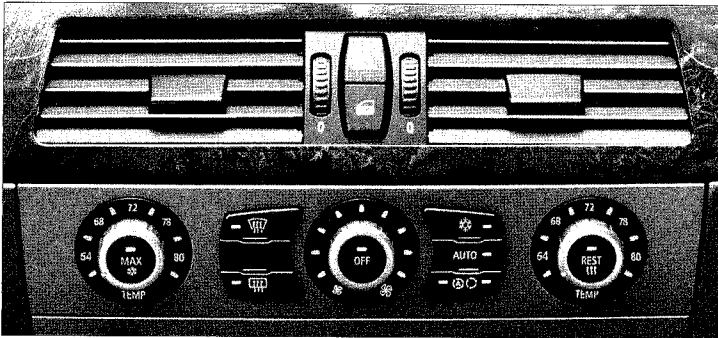

BMW offers two levels of automatic climate control in Europe, but all U.S. models have the “high” system. New features include rotary temperature controls, bi-directional

solar sensor, humidity control, climate-controlled console storage compartment and multiple defroster outlets.

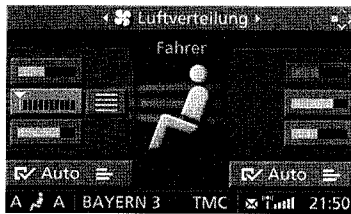

New to 5 Series, evolved from 7 Series: Individualization of airflow patterns is done on the iDrive monitor. This screen is for adjustment of airflow balance among footwell, dash and defroster outlets. *Luftverteilung* = air distribution; *Fahrer* = driver; the latter shows that air distribution is now separately adjustable for the driver and front passenger, a capability formerly reserved for the 7 Series only.

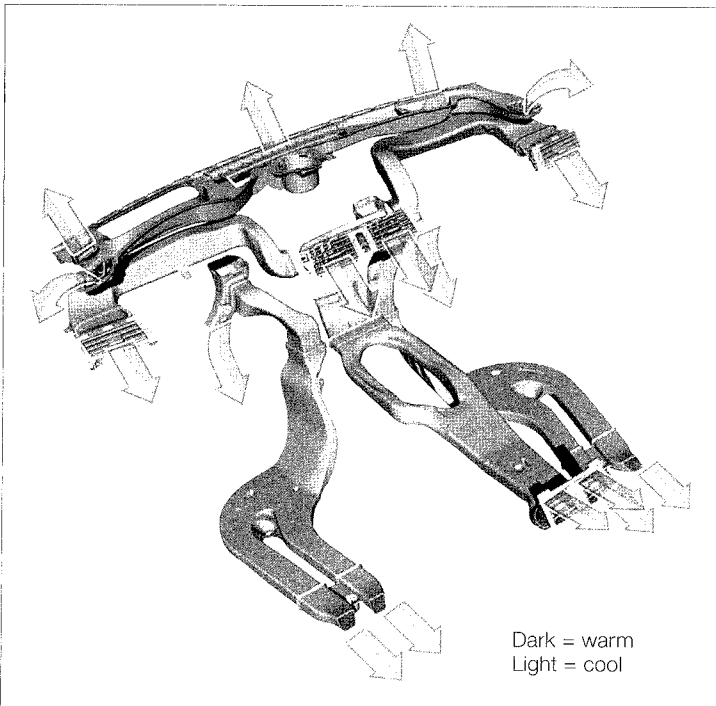

Dark = warm
Light = cool

- Inclusion of front footwells in left/right separation*
- Variable rear-compartment ventilation and heating
- Heat at Rest (allows heating the interior for a limited time with the engine off)
- Automatic ventilation (allows programming of interior ventilation during periods when vehicle is standing)
- Active-charcoal microfilter ventilation
- Bi-directional* solar sensor for front compartment (takes into account the direction of solar heat in determining cooling of interior)
- Storage of individual users’ climate settings in Vehicle & Key Memory
- Maximum a/c setting for rapid cool-down at a single touch of a button
- Automatic recirculation control, with specific sensing capability for diesel exhaust
- Layout of “hard” controls similar to that of Z4 Roadster, with rotary temperature and blower-speed controls*
- Humidity control* – avoids over-dehumidification. Previously, in a/c operation, air was always cooled to 32°-37°F, then re-warmed to the desired temperature; this could cause more de-humidification than desirable. Thanks to a new outside-temperature sensor, air is now cooled only as far as necessary, avoiding the over-dehumidification and improving comfort, particularly with regard to the mucous membranes.
- Climate-controlled console storage compartment*
- Multiple defroster outlets* to accommodate optional Head-up Display:
 - Main outlets, centrally located
 - Side outlets for defrosting in A-pillar areas
 - Outboard outlets for mirror-triangle areas and entire front side windows.

Other areas of functional improvement over the predecessor system (which itself is excellent) include:

- Faster warmup of the interior, particularly the front footwells, after a cold start.
- Improved distribution of warmed or cooled air throughout the interior.
- Further reduction in fogging of windshield and windows
- Quieter blower operation.

Rain-sensing windshield wipers and automatic headlight control: standard on all models

Benefits

- Two important features; formerly optional on 6-cylinder models
- Both features relate to convenience and safety

These two features were formerly optional on 525i and 530i models, standard on 540i models:

Rain-sensing wipers. A sensor mounted on the inside of the windshield measures the amount of rain impinging the windshield. Actuating the wiper control to its first “on” position puts the wipers in their rain-sensing mode; sensitivity to moisture can be adjusted by turning the rotary control on the stalk.

Automatic headlight control. Automatically switches on the headlights and all related lighting when ambient light drops below a certain level.

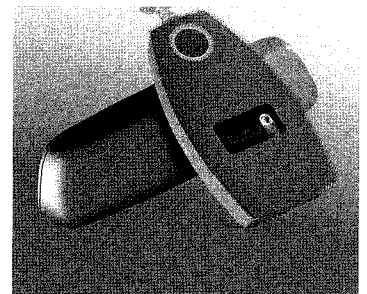

The rain sensor is mounted on the inside of the windshield, just ahead of the inside rearview mirror.

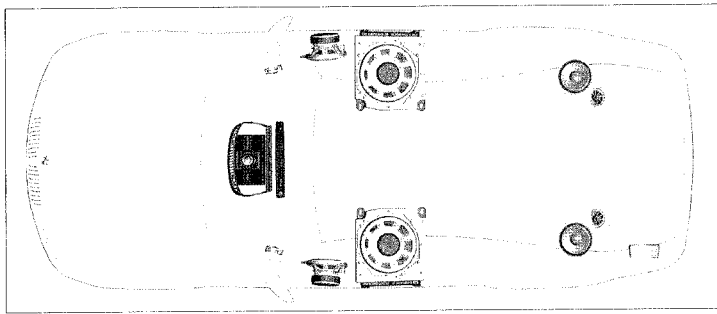

Audio systems

Benefits

- **Standard system improved; now includes 2 subwoofers**
- **Diversity antenna system repositioned for enhanced FM reception**
- **Optional premium audio system is essentially identical to the amazing Logic 7 system first offered in 7 Series**

As before, two audio systems will be offered: standard and optional premium via the Premium Sound Package.

The standard AM/FM/CD system includes 10 speakers, with subwoofers for the first time as part of a standard 5 Series system:

- 2 subwoofers, 210 mm, one each in cavities at the bases of the B-pillars
- 2 conical midrange, 100 mm, in the front doors
- 2 conical midrange, 100 mm, in the rear shelf
- 2 tweeters, 25 mm, in the front-door mirror triangles
- 2 tweeters, 25 mm, in the rear shelf.

As in the current Series, the circuits for a reception-enhancing diversity antenna system are integrated into the rear window. The amplifier for these circuits has been moved from a C-pillar to a central position just above the window, closer to the antenna circuits and thus further improving FM reception beyond the excellent level already offered by the current 5 Series.

A fin-type roof antenna serves the available phone system and/or the Navigation System, as well as the GPS aspect of the standard telematics system; the housing for this antenna (which is present on all models) also accommodates an antenna for

While still counting 10 speakers, the new standard audio system incorporates subwoofers for the first time in the 5 Series. The subwoofers are mounted in cavities at the bases of the B-pillars, though often referred to as being "under the front seats."

the Sirius Satellite Radio, which is available as a factory option. (Sirius availability is currently being phased in for other BMW models as a Center-installed accessory.)

The standard audio system includes BMW's now universally standard single-disc CD player. A 6-disc CD changer, similar to that in the 7 Series but mounted in the glove compartment rather than the dash itself, is offered as part of the Premium Sound Package or for Center installation in combination with the standard audio system.

The optional Premium Sound Package is essentially identical to the amazing Logic 7 system that's available in 745 models and standard in the 760Li. Its Digital Sound Processing (DSP) is adjusted on the color monitor, using the controller. For details on this system, see **options & accessories**, page 45.

Telematics and BMW Assist as standard equipment

Benefits

- **Telematics provide simple and convenient emergency and assistance functions**
- **BMW Assist offers a wide range of emergency, assistance and concierge services**

For the '04 model year, telematics and BMW Assist will become available in all BMW models without requiring the optional Navigation System. (These amenities are already standard in models that come standard with the Navigation System.) As is the case with BMW Assist now, the first year's subscription will be

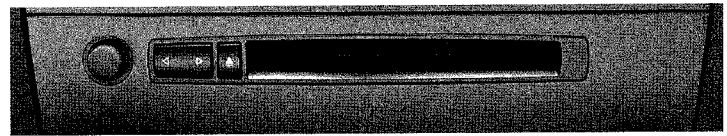

As in the 7 Series, basic audio-system controls and the single-disc CD player appear in "hard" form on the dash; other audio functions are executed on the iDrive monitor.

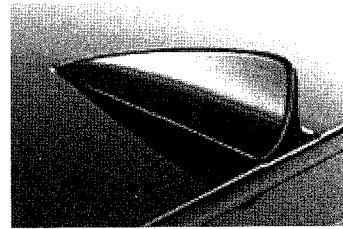

As in the previous 5 Series, the diversity antenna system shares the heating lines in the rear window; its amplifier has been moved to a central position just above the window for improved reception. The fin-type antenna housing can accommodate the wide range of available systems that require an antenna.

included in the new-vehicle purchase price, the customer paying thereafter. Current planning is to include telematics and BMW Assist in the 3 and Z4 Series' optional Premium Packages; in the 5 Series, these features will be standard. The 5 Series scheme is as follows.

Overhead SOS button. The SOS (Emergency) button is in the roof console. When it is activated, the hardware will transmit the location (via standard GPS technology in the vehicle) and the customer's phone number, as well as vehicle information, to the Response Center. A qualified representative will contact the occupants (via the standard wireless communication technology in the vehicle). If this contact is successfully established, the Response Center and the customer can communicate in a hands-free manner; an actual cell phone is not necessary, nor can the customer place calls unless an actual cell phone is present. If, in the case of an Emergency call,

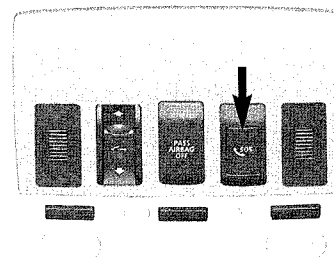

SOS button (arrow) is conveniently positioned in the roof console; soft control for BMW Assist calls is in the iDrive monitor.

the customer does not reach the Response Center, the system automatically calls 911. Or if the customer's call does reach the Response Center but the Center cannot then contact the customer, the Center contacts the appropriate emergency services and informs them of the location of the emergency situation.

Roadside Assistance. The BMW Assist button is a soft key in the iDrive monitor, as part of the Communications menu, and is used to establish Assistance communication with the Response Center. As with Emergency calls, the relevant information is transmitted to the Center, and Center personnel contact the customer as described above.

Automatic notification upon airbag deployment. Already present in current models with a BMW Cellular Phone System, this feature becomes standard in all '04 5 Series models.

New functions. Although in current planning only the overhead SOS button and Assistance soft key are assured for start of production, further functions may be added:

- Customer Service – activating this soft key puts the customer directly in touch with BMW Customer Service.
- Request service appointment – connects the customer directly to a preferred BMW Center Service Department.
- Automatic service-appointment request – As in the 7 Series, the Check Control system tracks specific service requirements. When the system determines that such service is due, the preferred BMW Center Service Department would be notified automatically, and that Department would then contact the customer to schedule an appointment. (This feature isn't included in the 7 Series yet.)

For further information on BMW Assist, see page 342, Fast Facts 2003-2004.

Upholstery and trim

Benefits

- **Choice of leatherette or new Dakota leather in 525i and 530i; leather standard in 545i**
- **Metallic finishes set attractive accents to upholstery and woods**
- **Maple Anthracite wood trim is an appealing and unique new option**

Once again, leatherette upholstery is standard in the 6-cylinder models. New Dakota leather upholstery (stand-alone option or Premium Package in the 6-cylinders, standard in the V-8 545i) is softer and more luxurious than the former Montana grade. Color-keyed interior trim continues in the 525i and 530i models; this appears in a deep strip across the dash, separating color zones 1 and 3 and on the center console.

Door panels are handsomely upholstered, contoured and trimmed; the door pulls and interior door handles of all models are finished in a metallic-look material called Titanium II. The dash and console are trimmed in a color-keyed material (standard 525i/530i) or **Dark Poplar wood** (525i/530i Premium Package, 545i standard). An alternative wood trim, **Maple Anthracite**, is available at no extra cost in

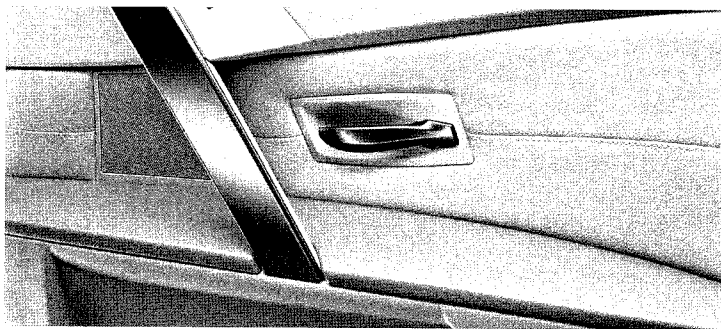

Door pulls and interior door panels are finished in a metallic-look material called Titanium II.

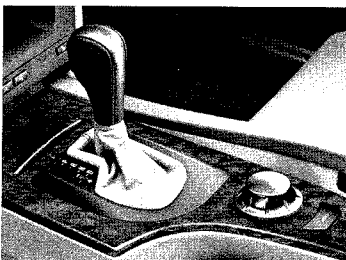

Dark Poplar wood interior trim is included in the 525i and 530i Premium Packages, and is standard in the 540i.

Premium Package-equipped 525i and 530i models and in any 545i. The gray wood is especially distinctive, and harmonizes well with all interior colors.

Wood trim is to be added to the door pulls of both wood options at a later, as yet undecided date.

Front seats: many choices

Benefits

- **10-way power seats are standard**
- **Sport seats (included in Sport Packages) can now be combined with power lumbar support**
- **20-way Comfort seats (optional) offer new features and capabilities compared with previous 16-way Comfort seats**

As in the predecessor Series, standard 10-way power front seats include these adjustments:

- Fore-aft position
- Seat height
- Seat angle
- Backrest angle
- Head-restraint height.

The power controls are on the outboard edge of each front seat, are shaped analogous to the seat portions they control, and can be operated intuitively and without looking at them. The driver's-seat memory controls

have been moved from the driver's door to the same panel as the power controls; these are now capable of capturing two preferred positions for each user (via Key Memory and the individual user's remote) – actually an improvement over the former total of three memory settings.

4-way power lumbar support is included in the 525i and 530i Premium Package, and offered as a stand-alone option for the 545i models.

The **sport seats**, once again included in the Sport Package for each model, add power-adjustable thigh support (in the form of a movable front cushion section), and now accommodate something that was previously unavailable in the 5 Series sport seats: 4-way power lumbar support. Thus in 6-cylinder models with Sport and Premium Packages and in any 545i, they include fully 16-way power adjustment.

Replacing the former 16-way Comfort front seats are **new multi-function Comfort seats**, similar to those offered in the 7 Series. Continuing the Comfort seats' power-adjustable upper backrest sections, they add power adjustments for –

- Thigh support

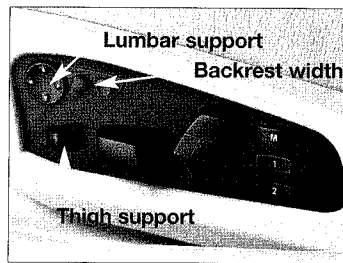

Power and memory controls for the 20-way Comfort front seats.



The standard front seats in all models incorporate 10-way power adjustment, with their controls (including memory) on the seats' outboard edges.

- Backrest width (the backrest's side bolsters spread or narrow to accommodate the occupant's back and shoulders)
- Fine adjustment of head-restraint height.

Thus these seats offer **20-way power adjustment**, plus memory for both seats. Head-restraint height is coupled with the fore-aft position as on the standard seats, but fine adjustment is powered (standard seats: manual). Head-restraint angle is manually adjustable on all 5 Series front seats. The head restraints also incorporate adjustable side extensions that help support the head of an occupant using them as headrests, as for example when sleeping. The Comfort seats' head restraints also provide **active** protection in rear-end impacts; see **safety & security**.

Also new is a **heated rear seat**, available as a stand-alone option in combination with the Cold Weather Package. Controls for heating the two outboard seating area are at the bottom of the center console's aft end.

In the 6-cylinder models, all seating options require ordering leather upholstery, either in the Premium Package or as a stand-alone option.

Between the seats, a versatile console

Benefits

- **Storage space increased over previous 5 Series**
- **2-part compartment with climate-controlled lower section**
- **Driver's portion of padded cover is adjustable for use as armrest**

Generous storage space is provided in the console's rearward portion. On the right side is a padded lid that serves as the passenger's center armrest;

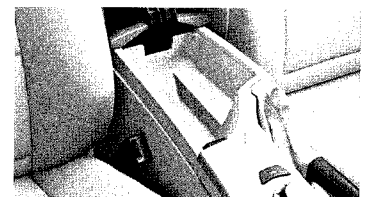

Shown with its lid raised, the center console compartment has two levels: upper, seen here; and climate-controlled lower portion.



Durable, attractive leatherette continues as the standard upholstery in the 6-cylinder models (525i, 530i); Dakota, a softer and

more luxurious grade of leather and new to the 5 Series, is optional in the 6-cylinders and standard in the V-8 545i.



Newly designed rear-seat structure provides standard or fold-down seats with no variation of the body structure itself.

when released, this lid springs up to 35° and can then be opened wider. Underneath is a 2-part compartment: upper, which can accommodate a phone handset, and a climate-controlled lower compartment. The padded left side can be moved forward by 60 mm (nearly 2.5 in.) to give the driver two positions to choose from.

Rear seat: more room, and innovations here too

Benefits

- 1.8 in. more leg room, 0.7 in. more head room and 1.3 in. more shoulder room
- Includes 3-point safety belts and head restraints at all seating positions
- Fold-up center armrest includes dual cupholders
- For security, available folding seatbacks can be released only from inside trunk

Although the rear seat looks conventional enough, it incorporates a behind-the-scenes (literally!) innovation in the form of a newly conceived backrest frame and bulkhead.

Up to now, the 5 Series sedan body has been produced in two variations: with different steel bulkheads for the fixed rear seatback and the folding rear seats/ski bag option. The new body is produced in only one version. The seat backrest itself consists of a "hybrid" wall, a rigid welded steel frame and plastic shell, that is fastened to the body at four points. This shell itself forms the bulkhead and is made in the two versions; in addition, no sound insulation is necessary here, as the shell does not transmit noise like a conventional steel bulkhead.

In a similarity to the 3 Series Sport Wagon, the center armrest includes a head restraint that is functional when the armrest is folded up; this is not adjustable. The outboard head restraints are manually adjustable. Rear cupholders are incorporated into the center armrest.

The rear seat is roomier all around; this drawing illustrates its increased leg room (new E60 vs. previous E39).

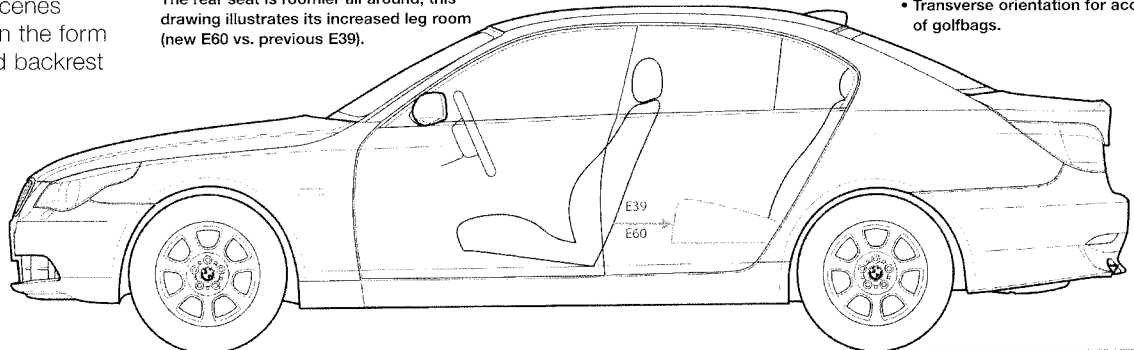

Four power outlets

Benefit

- Conveniently located power outlets for various electrical accessories

For the first time in the 5 Series, power outlets for electrical accessories are included. There are four:

- In the front passenger's footwell
- Two at the aft end of the center console, for rear-seat passengers
- In the trunk.

Roomy trunk with numerous new features

Benefits

- Fully 26% more cargo space than before
- Single-link tubular hinges do not protrude into trunk
- Reversible mat

Evolving in much the same way as that of the 7 Series, the E60 trunk gets a similar "transverse

orientation" that allows it to accommodate four golfbags laterally (4 x 45 in. or 3 x 46 in. + 1 x 45 in.). The toolkit continues to be mounted conveniently on the trunklid's underside, and contains the same set of tools as in the 7 Series.

Also shared with the 7 Series are the single-link tubular hinges, which eliminate any intrusion of the hinges into the trunk space. Automatic trunk opening/closing, however, is not offered on U.S. 5 Series models.

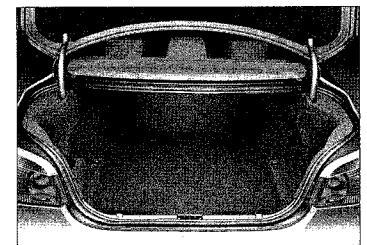

The trunk incorporates thoughtful functional features first seen in other Series, including -

- High trunklid, contributing to significantly greater cargo space
- Single-link tubular hinges that eliminate any intrusion into the trunk space
- Reversible floor mat: flock on one side, slide-resistant rubber finish on the other
- Transverse orientation for accommodation of golfbags.

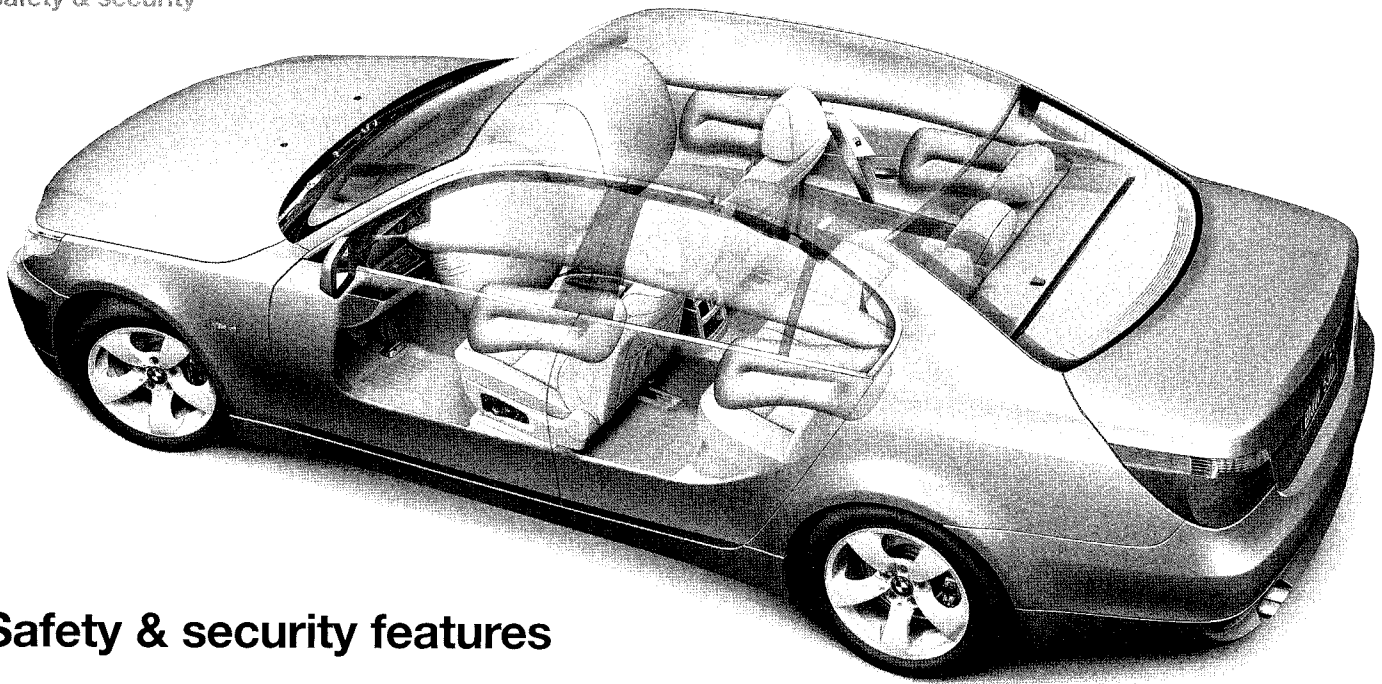

Safety & security features

In terms of direct customer concern and interest, it is the safety devices and systems – airbags, safety-belt tensioners and so forth – that are most relevant to occupant safety. Here, as one expects of a new-generation BMW, the 2004 5 Series is truly state-of-the-art.

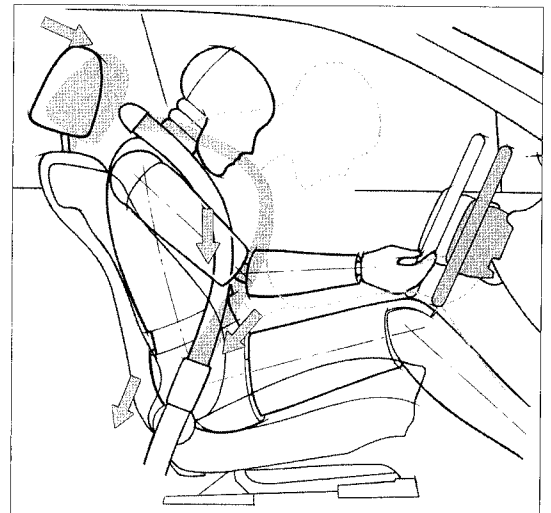

As with the 7 Series, BMW safety engineers have developed a fixed upper anchor point for the front safety belts that functions optimally for virtually all occupant statures.

Evolved safety-belt system

Benefits

- **Optimized upper anchor point for front belts enhances comfort without an adjustment**
- **Front belts include automatic tensioners and force limiters**
- **Automatic tensioners newly available for rear outboard belts**

Some customers may be surprised to discover that the front safety belts do not include the customary adjustment of their upper anchor point (this is manual in 3 Series closed-body models and X5s, linked to fore-aft seat adjustment in the current 5 Series). As for the 7 Series, BMW's safety engineers have developed an optimized upper belt anchor point with the following advantages:

- It functions equally well for all seat positions (and occupant statures).
- Reduced friction where the belt passes through this point increases the occupant's belt-wearing comfort, as well as its restraint function in an impact.
- The anchor assembly is designed to deform if impacted by an occupant's head.

For the first time in the 5 Series, the option of rear-seat side-impact airbags includes automatic tensioners for the rear safety belts. (See **options & accessories**.) Like those in the front, the pyrotechnic tensioner mechanisms are integrated into the belt latches. As in the current

5 Series and other BMW models, the front belts also include force limiters to limit the force exerted by the belt on the occupant's body.

Significantly evolved front-impact airbags

Benefit

- **Airbags further optimized for occupant protection**

The airbag systems are an evolution of those in the 7 Series. Both front-impact airbags have been further developed to optimize their 2-stage, accident-severity-dependent deployment characteristics, their inflated shape, and their interaction with surrounding surfaces and components.

All models have a 3-spoke steering wheel with relatively small center hub, so the driver's airbag is notable for its compactness. The passenger's-side airbag also shows some evolution in that its cover atop the dash's right side is 2-piece, the forward portion opening toward the windshield and the rearward toward the interior. This further optimizes the airbag's unfolding sequence and protective capability.

Unlike the 7 and Z4 Series, the new 5 Series does not incorporate Active Knee Protection via underdash airbags. With the further structural development included in the E60 project, this measure became unnecessary to achieve occupant-protection goals.

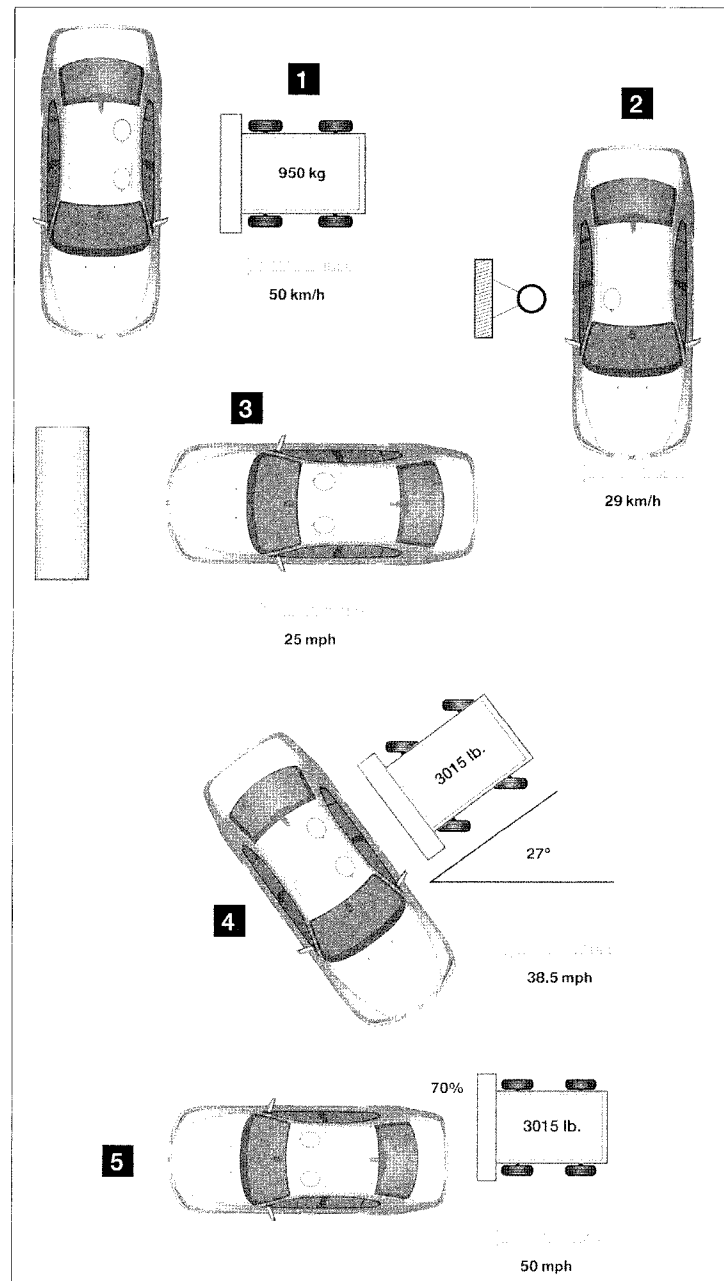

Among the vast array of crash tests conducted on the new Series to optimize its occupant protection:

- 1 - 950 kg (2094 lb.) into vehicle side at 50 km/h (31 mph)
- 2 - Post impact into vehicle side
- 3 - 25 mph into fixed barrier
- 4 - 3015 lb. into vehicle side at 38.5 mph and 27° (angled impact)
- 5 - Offset rear-ender, 3015 lb. into rear of vehicle at 50 mph with 70% coverage.

"Round" metric weights and speeds indicate a European standard; round English units indicate a standard set by the U.S. government.

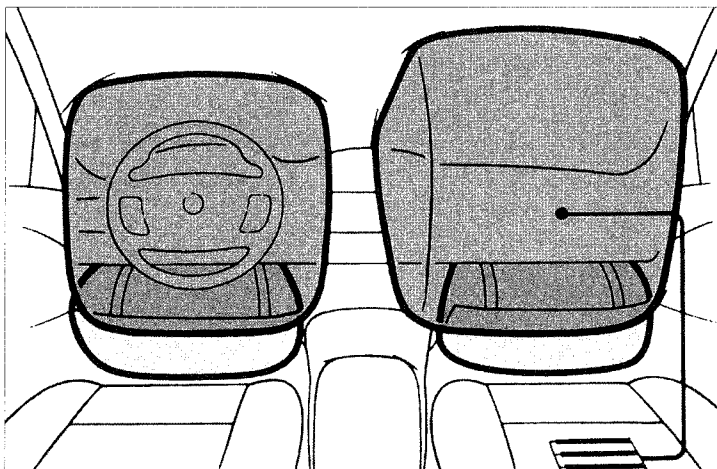

Both front-impact airbags have been further developed to optimize their 2-stage, accident-severity-dependent deployment and other characteristics.

Front and rear Advanced Head Protection System (AHPS II)

Benefits

- Offers outstanding protection to occupants' heads in crash impacts
- Integrated front-to-rear system

The 5 Series is the second BMW Series to employ AHPS II; this replaces the current 5 Series system of separate front and rear Head Protection Systems with an integrated front-to-rear system.

AHPS II extends all the way from the A-pillar to the C-pillar, with a "sail" connecting the inflatable tube to the roof structure between these two points. The sail is of airbag-type material; between it and the long inflatable tube itself, essentially all body-side and side-window areas likely to be impacted by an occupant's head are covered by the system.

According to BMW safety engineers, the front/rear AHPS II –

- Combines the best protective attributes of BMW's familiar HPS and competitive "curtain"-type systems.

- Offers the same advantage as the front-only HPS in extended crash sequences (such as a rollover) in that after deployment, it remains inflated for approximately 7 seconds.
- Because of its relative rigidity once inflated, provides protection against shattered glass and intrusions from the outside.
- Can protect persons of small or large stature.

Active Head Restraints (optional front Comfort seats)

Benefits

- Add protection for front occupants in rear-end crashes
- Allow occupants to adjust head restraints to personal comfort preferences, yet retain optimum protection

Via two additional impact sensors at the rear of the vehicle, a rear-end collision causes the front head restraints to pivot forward into close proximity with the occupants' heads. Thus occupants are able, if they prefer, to adjust the restraints away from

direct contact with their heads during normal vehicle use, yet in the case of a rear-end impact gain optimum protection against neck and head injuries. This feature is also present in the 7 Series' front Comfort seats.

Ultra-sensitive "satellite" side-impact sensors

Benefit

- Optimize occupant protection in side impacts

As in the 7 and Z4 Series, an advanced type of "satellite" sensor detects side impacts and triggers deployment of the side-impact airbags. (Front-seat side-impact airbags are standard, rear-seat ones optional.) By sensing pressure change within the door structure, they are able to signal for deployment very early in a side impact, yet still minimize the chance of an unwanted deployment.

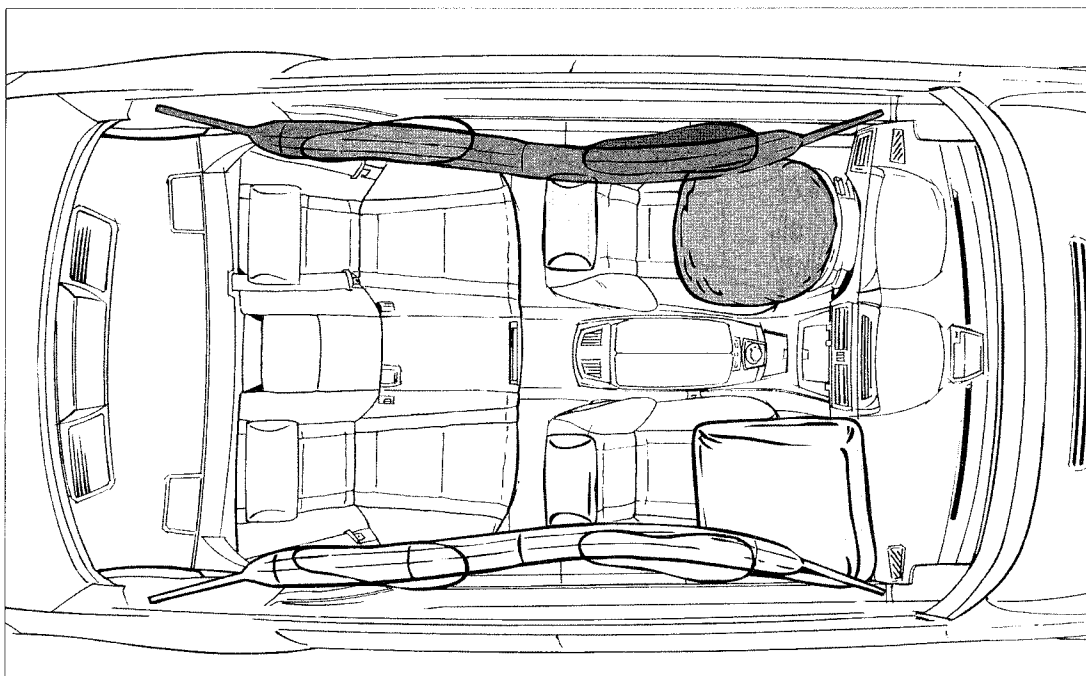

The 5 Series is the second BMW Series to incorporate BMW's excellent front and rear Advanced Head Protection System (AHPS II).

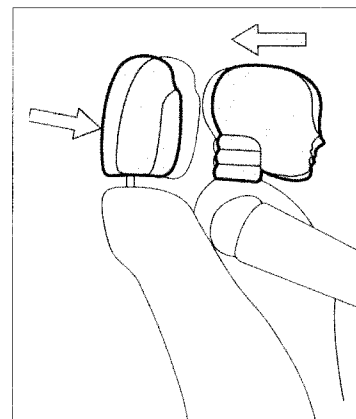

Active Head Restraints are included with the optional front Comfort seats. Via two dedicated impact sensors at the rear of the vehicle, a rear-end collision causes these restraints to pivot forward into close proximity with the occupants' heads, even if occupants have adjusted them farther back.

Interlocking door anchoring system for side impacts

Benefit

- Enhances the vehicle body's impact resistance in side impacts

This remarkable feature, which has enhanced the inherent side-impact safety of 3, 5 and 7 Series vehicles for many years, continues in the new 5 Series. In each door is a diagonal aluminum reinforcing bar. The bar's aft end is anchored to a hook-like member that, in the event of a serious side impact, "grabs" the body pillar as the door deforms. In this manner, the front door is interlocked with the B-pillar, the rear door with the body's rear quarter; this helps hold the body side together as a unit that resists the side impact. The system is designed so that after most impacts, elastic "snap-back" releases the hook and the doors can be opened.

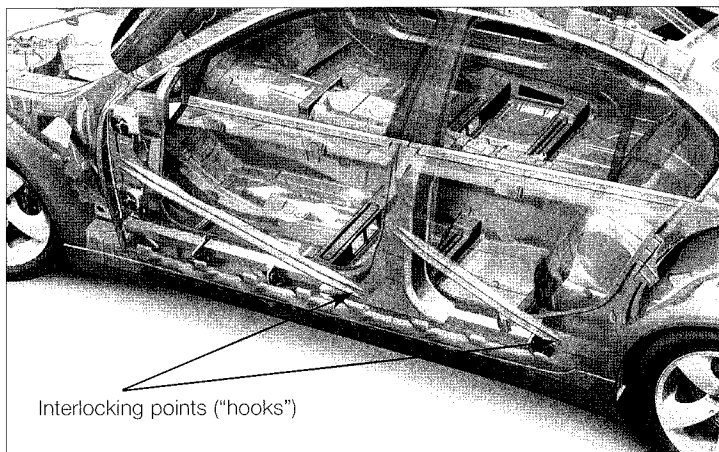

In a serious side impact, "hooks" at the ends of the doors' reinforcing bars and the door edges "grab" the body sides to tie the side structure for great impact resistance.

Intelligent Safety and Information System (ISIS)

Benefits

- Optimally tailors deployment of safety systems to actual accident circumstances
- Enhances reliability of safety systems
- Allows updating of system software over life of vehicle
- Facilitates gathering data from accident vehicles

ISIS is the overall control system for the vehicle's safety systems and devices. After a decisive leap forward upon introduction of this system in the new 7 Series, the 5 Series system is a further evolution of safety technology.

ISIS is a decentralized system, with an overall SGM (Safety Gateway Module) and seven subordinate control units, each with a microprocessor of its own. This multiplicity of units provides a redundancy that

helps preserve system reliability even when portions of the system are damaged and knocked out by accident damage.

In interaction with the main and subordinate control units, the ISIS employs fully 14 sensors. Together, these sensors achieve remarkable "tailoring" of the deployment of the airbags, Battery Safety Terminal and safety-belt tensioners to actual accident circumstances. Supporting the ultra-sophisticated electronic control scheme itself, fiber-optic cables are not susceptible to extraneous electromagnetic disturbances. System software can be updated over the life of the vehicle; data useful to researchers can be retrieved from accident vehicles.

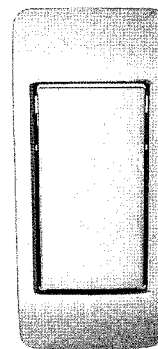

Passenger Airbag Off switch is a new safety feature.

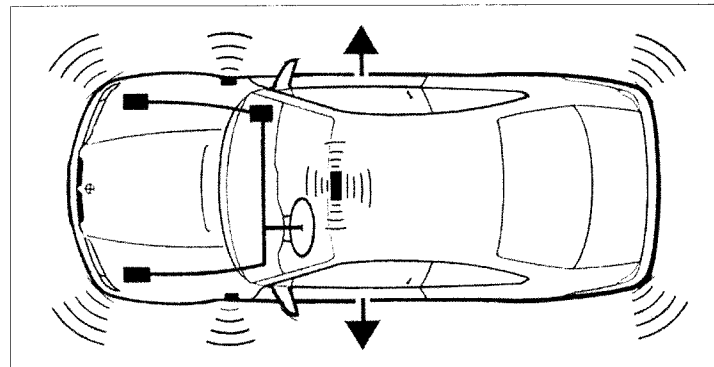

In interaction with the main and subordinate control units, the Intelligent Safety and Information System (ISIS) evaluates crash impacts of many types and from various directions to achieve a remarkable "tailoring" of safety functions to actual accident circumstances.



Options & accessories

The range of factory options and BMW Center-installed accessories is multi-faceted. Some, like the Premium and Cold Weather Packages and stand-alone leather option for the 6-cylinder models, are continuations of familiar 5 Series choices. Others, such as a choice of two different wood interior trims, Head-up Display, Active Steering and Active Cruise Control, are brand-new to the Series. Read here about all the choices: new and familiar factory options, plus familiar Center-installed accessories in new forms.

Factory-installed options

Premium Package

(525i & 530i, code OZPP)

Benefits

- **Combines luxury features (most of which are standard on 545i) into a value-priced Package**
- **Includes features not previously available in 5 Series**

A familiar concept for the 6-cylinder 5 Series models, this Package adds familiar and new features to their new E60 counterparts. Except for power lumbar support (offered as a stand-alone option for 545i

models), all content of this Package is standard on the 545i. New features or details are denoted with an asterisk:

- **Dakota* leather upholstery**, as described on page 34.
- **Dark Poplar wood trim.**
- **Design Light Package**, consisting of –
 - LED ground lighting* in the exterior mirror housings. Illuminates along with interior lighting, including switching on when the vehicle is unlocked via the remote. Brightness is controlled along with that of the instrument lighting.

- Illumination at interior door handles and door storage bins (in same manner as the overhead BMW Ambiance Lighting)
 - Front footwell lighting
 - Exit/entry lighting in rear door panels (front standard)
 - Additional trunk lighting (in trunklid)
- **4-way power lumbar support** for the front seats.
- **Auto-dimming exterior* & interior mirrors.** This is the first appearance of auto-dimming exterior mirrors on regular-production 5 Series models. (They are standard on the current M5.)
- **BMW Universal Transceiver**, the familiar 3-function device that can operate garage doors and other external electrical devices or systems.



New Dakota leather upholstery, available in the Premium Package or as a stand-alone option for both 6-cylinder models, is even

softer and more luxurious than the Montana leather used previously.

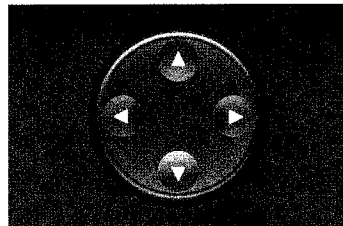

Power lumbar support is controlled by this 4-way switch on the outboard edge of each front seat.



Auto-dimming exterior mirrors appear in the 5 Series Premium Package for the first time.

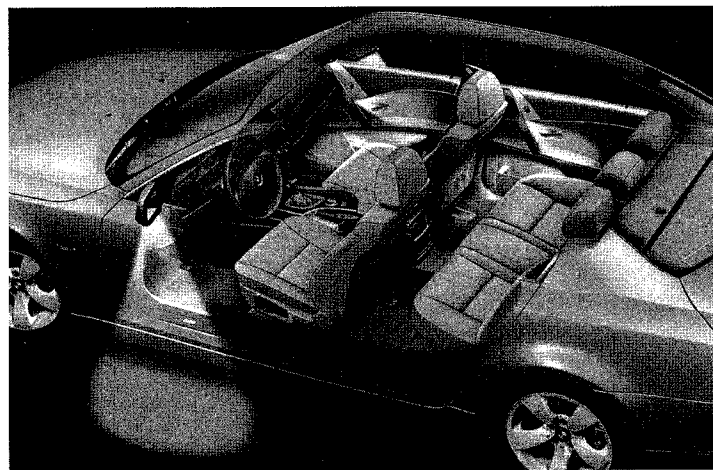

LED ground lighting is a new Premium Package feature, and one of several premium lighting amenities included in the Package.



The new moonroof has a larger opening than that of the previous 5 Series.

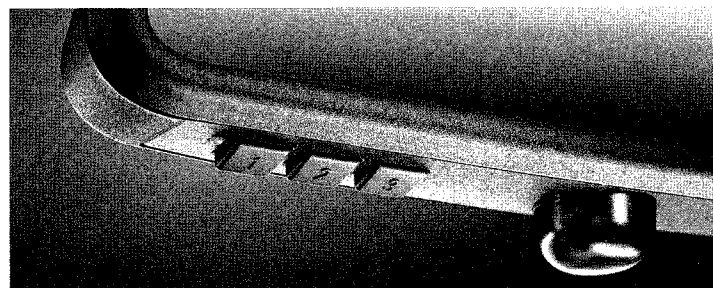

The Universal Transceiver can be programmed to operate three functions remotely.

Options & accessories

Sport Package

(all models, code OZSP)

Benefits

- Available throughout the line, specifically tailored to each model
- Includes Active Steering and Active Roll Stabilization, which help achieve the most amazing BMW Sedan steering and handling ever
- Includes run-flat performance tires, which enhance handling and add convenience in case of a flat tire

This Package, essentially the same for all three models but with different wheel-and-tire equipment for each model, includes some of the Series' most exciting new technology. Again, new features or details are denoted with an asterisk.

- **Active Steering***. This brand-new, exclusive BMW feature makes its debut on the 5 Series and introduces heretofore unheard-of benefits.

Variable ratio. Active Steering electronically varies the steering ratio (that is, the number of degrees the steering wheel must be turned to achieve a 1° steering angle at the front wheels) on the basis of vehicle speed and other driving conditions. The variation in steering ratios is considerably greater than that achievable by purely mechanical means (such as the 5 Series' standard variable-ratio steering gear) – so great, in fact, that steering-wheel movements required in parking maneuvers, U-turns and sharp corners are greatly reduced. This results not only in greater convenience, comfort and feeling of vehicle agility, but controls located on the steering wheel – such as the multi-function buttons on the wheel's face and the Sequential Manual Gearbox's shift paddles – can be operated more easily and naturally while the driver is steering.

Optimized driving dynamics.

The Active Steering system measures many factors of operating conditions, and varies the steering ratio to enhance dynamics, i.e. the vehicle's response to the steering wheel.

Vehicle stabilization. In situations that would normally reduce the vehicle's stability, Active Steering can intervene to preserve stability.

Authentic steering feel.

Because Active Steering retains a direct mechanical connection between the steering wheel and the steered wheels, and steering assist is applied in a proven BMW way, authentic steering feel is retained.

Reliability. The direct mechanical connection and a fail-safe provision ensures that even if there is a system failure the driver can still steer the vehicle.

Here's how Active Steering works.

First, we have the steering column, taking motion down to the hydraulically assisted rack-and-pinion steering gear between the front wheels. Now, Active Steering interposes a planetary gearbox in the steering system, positioned at the bottom of the steering column to increase or decrease the amount of rotation there relative to the driver's turning of the steering wheel. The planetary gearbox is electrically driven; the degree to which it adds to, or subtracts from, the driver's input is determined by several electronically measured factors:

- Vehicle speed. We want less power assist as speed increases: more at low speeds to help us park and maneuver, less at high speeds for a firm feeling of the road and how the vehicle is relating to it. (Servotronic power assist provides this.) The vehicle-speed input also feeds into Active Steering, which causes the little gearbox to add to the driver's steering-wheel motions (and therefore reduce the effective steering ratio). This addition gradually decreases until a speed of approximately 75 mph is reached, at which point the system neither adds nor subtracts. Above this speed, the system begins to subtract, enhancing stability at high speeds.

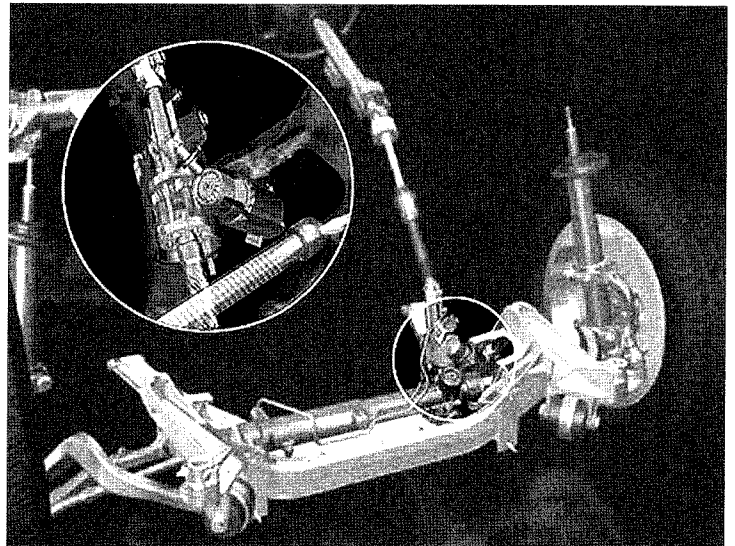
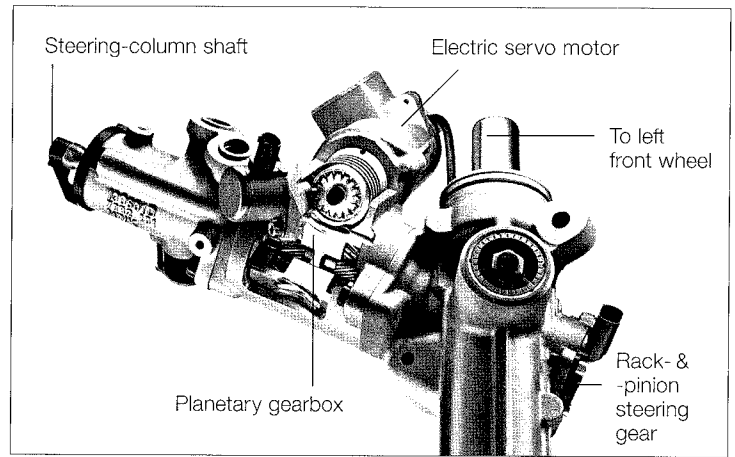

Electrically driven planetary gearbox (shown in cutaway at top and in the larger circle just above)

driver's turning input to the steering wheel to vary the steering ratio according to driving conditions.

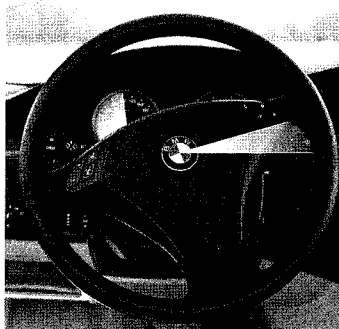

At low to medium speeds, Active Steering reduces the amount of turning at the steering wheel to negotiate a given curve or corner. Above, a typical Active Steering motion at low speeds...



...and here the motion required for the same steering of the front wheels at higher speeds.

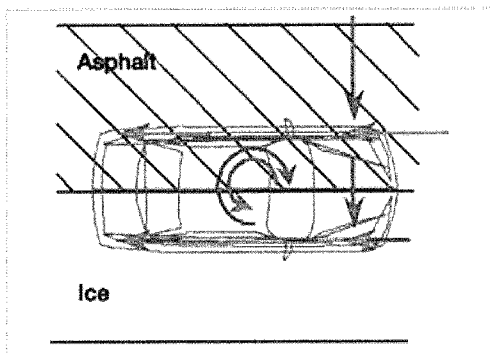

Applying the brakes when the two sides of the vehicle are on different road surfaces can induce instability. Active Steering automatically takes corrective action to help stabilize the vehicle under these circumstances.

Braking on unequal road surfaces:

← Braking force

Induced by automatic steering compensation:

↓ Lateral force

↻ Yaw moment

↻ Yaw moment

- Stability. Active Steering can add stability – even beyond the effect already provided by Dynamic Stability Control. Via its inputs of vehicle speed and steering angle, the system can compare the actual vehicle motion with that desired by the driver. Even at small deviations from the desired motion, Active Steering can (unnoticed by the driver) adjust the steering to enhance stability.
- Uneven road surfaces. If the driver applies the brakes while the vehicle is moving on a surface with uneven traction – for example, if one side of the roadway is slick and the other offers good traction – the brakes’ uneven effect on the two surfaces can produce a strong tendency for the vehicle to pull to one side (yaw). Under such conditions, Active Steering recognizes and measures the incipient instability and steers against it. The driver does not have to correct, and is most likely not even aware that the system is doing it.

Other major technological features of the Sport Package are –

- **Servotronic power assist.** Another element of the Active Steering system is Servotronic power assist, which is vehicle-speed-sensitive. Compared to the standard engine-speed-sensitive power assist, Servotronic reduces steering effort (the effort the driver must exert on the steering wheel for a given maneuver) more significantly at low speeds and at a standstill.

Already a benefit in the relatively heavy 7 Series and M5 models where it is also standard, Servotronic is especially advantageous given the very “quick” steering ratio that Active Steering provides under certain operation conditions – such as parking and low-speed maneuvers. The power assist is hydraulic¹⁰.

- **Active Roll Stabilization (ARS).** First introduced on the 7 Series, where it is standard, ARS dramatically reduces roll, or the tendency of any motor vehicle’s body to “lean over” in corners, curves or any other steering maneuver. This improves handling by virtue of improved suspension geometry (wheel angles relative to vertical), but there is a psychological component as well: drivers and passengers alike marvel at the “flat cornering” it engenders. ARS consists of –
 - Active anti-roll bars, replacing conventional purely mechanical (“passive”) front and rear bars. Each bar consists of left and right portions, twisted in opposite directions by a hydraulic motor between them.

- A valve/sensor block containing various system valves and sensors.
- A lateral-acceleration sensor to detect how hard the vehicle is cornering.
- An electronic control unit (ECU) regulating the entire system.
- A tandem oil pump which, via its two sections, provides hydraulic pressure for ARS and the power steering.
- An oil cooler, reservoir, filter, oil-level sensor and the various hoses, mounting brackets and other minor components.

Whenever the vehicle enters a corner or curve, or begins an avoidance maneuver, “lateral acceleration” is generated. This is read by the sensor, which transmits a signal to the ECU. The ECU processes this signal and transmits it to the valve/sensor block. In turn, the valve/sensor block determines the

hydraulic pressure to be applied to the active anti-roll bars to control body roll. The key word here is “active.” Active Roll Stabilization –

1. Generates resistance to body roll by twisting the front and rear anti-roll bars.
2. Does so in a stronger and more highly “tailored” way than can conventional anti-roll bars.
3. Does not offer resistance to bumps in straight-ahead driving, as conventional anti-roll bars inevitably do¹¹.
4. Increases the vehicle’s maximum cornering capability.
5. Improves steering response, particularly in the range of cornering where body roll is most tightly controlled.

Though it delivers similar benefits, ARS differs from the Active Body Control (ABC) system that Mercedes-Benz offers on its CL coupes and S 600 sedan (standard) and S 430/S 500 sedans (optional at \$3,020).

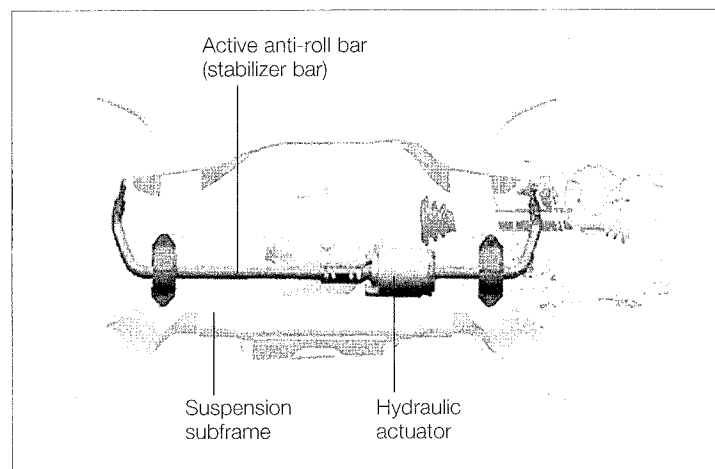

Active Roll Stabilization dramatically reduces body roll, or “lean,” by sensing the vehicle’s cornering and (via a hydraulic motor) twisting

the two anti-roll bar portions in opposite directions.

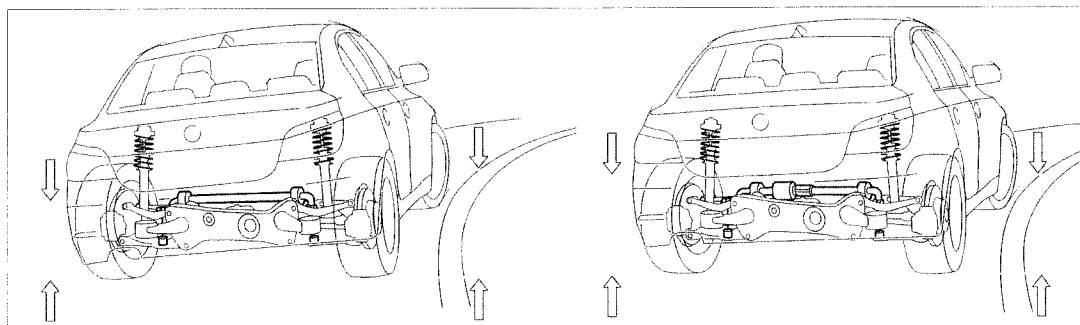

Active Roll Stabilization brings a new dimension of “flat cornering” to Sport Package-equipped E60 models. At left, without ARS; at right, with ARS.

¹⁰ – The Z4 Series employs electric assist, that is, steering assist is supplied by an electric servo motor. In all other Series, including the new 5 Series, steering assist is supplied by a hydraulic pump.

¹¹ – BMW has achieved great sophistication in the way conventional anti-roll bars work – as evidenced by the superb handling and riding comfort of all contemporary BMWs.

Options & accessories

Mercedes' system is more complex; it employs a hydraulic actuator at each wheel, eliminating anti-roll bars altogether. The actuators are "rams" or plungers atop each spring strut; in a corner, these rams push downward on the outside wheels' struts and pull upward on those at the inside wheels. ABC offers the driver a choice between two levels of roll control, Sport and Comfort – the latter allowing more body roll. ABC also influences riding qualities in a certain range. Over a road surface that might set the body into gentle pitching or heaving motions – called "float" – ABC plays a role in controlling the body; over road surfaces that would generate more nervous, "jiggly" body movements, ABC does not act.

With its application directly to the components most affecting cornering – the anti-roll bars – BMW feels that ARS is an appropriate solution for BMW's dynamic handling. Together with the revolutionary Active Steering, the other Sport Package chassis features (described next), and the sheer excellence of the new overall chassis concept, ARS brings 5 Series handling to a level that can be described as phenomenal, astounding – all the superlatives one can conjure up.

The more traditional Package features are –

- **Sport suspension.** This more traditional BMW Sport Package feature means firmer springs and shock absorbers. The usual larger conventional anti-roll bars are, of course, omitted because ARS is present. As usual with BMW Sport Packages, ride height is lowered by 15 mm/0.6 in.
- **Sporty wheels and run-flat tires.** Described on page 22, the Sport Package wheels and tires differ from the three models' standard equipment as follows:
525i – 17 x 8.0 wheels with 245/45R-17 W-rated run-flat performance tires, vs. the standard 16 x 7.0 with 225/55R-16 V-rated all-season.

530i – 18 x 8.0 wheels with 245/40R-18 W-rated run-flat performance tires, vs. the standard 17 x 7.5 wheels with 225/50R-17 V-rated all-season.

545i – 18 x 8.0 front/18 x 9.0 rear wheels with 245/40R-18 front / 275/35R-18 rear W-rated run-flat performance tires, vs. the standard 17 x 7.5 wheels with 225/50R-17 V-rated all-season.

In each case the wheels are of a different design from the standard ones, and each model has its own specific design as well. This is the most striking array of wheel/tire equipment ever offered on the 5 Series!

For valuable peace of mind, a space-saver spare is included.

- **Satin Chrome Shadowline exterior trim.** All-black trim around the side windows replaces the standard black-plus-chrome treatment.
- **12-way power front sport seats.** In addition to the standard 10-way power adjustments (including head-restraint height), these add power-adjustable thigh support for a total of 12-way power adjustment. Up to now, adjustable lumbar support has not been available in 5 Series sport seats; now it is available, via combining the Sport and Premium Packages.

Cold Weather Package (all models; code OCWP)

Benefit

- **Combines three weather-oriented features into a value-priced Package**

In contrast to the present Package, that for the E60 will include the heated steering wheel; its control switch has been moved from the steering-wheel face to the steering column's left side (as in the 7 Series). Package contents include:

- **High-intensity headlight cleaning system** with new retractable jets.
- **Heated front seats.** Incorporating refinements first seen in the 7 Series, these are available in two forms:

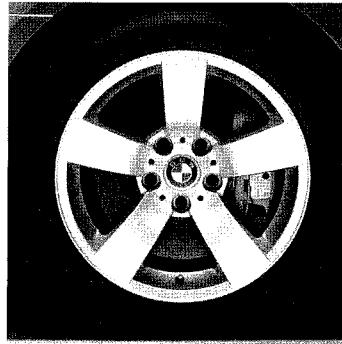

525i Sport Package wheels are 17 x 8.0 Star Spoke, design #122, with 245/45R-17 W-rated run-flat performance tires.

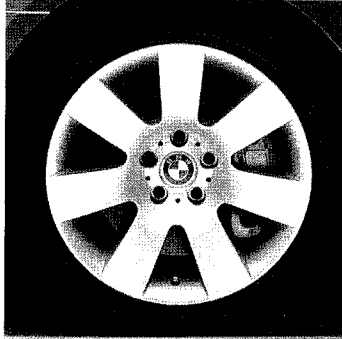

530i Sport Package wheels are 18 x 8.0 Star Spoke, design #123, with 245/40R-18 W-rated run-flat performance tires.

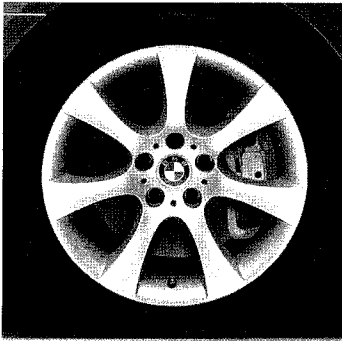

The 545i Sport Package includes this sportiest of E60 wheel-and-tire equipment: Star Spoke wheels (design #124), sized 18 x 8.0 front/18 x 9.0 rear and carrying 245/40R-18 / 275/35R-18 W-rated run-flat performance tires.

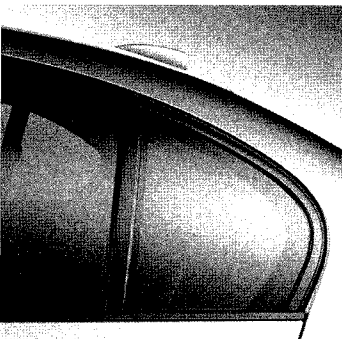

Shadowline exterior trim replaces the standard black-and-chrome side-window trim with all-black.

- With standard or sport seats – 3-stage/2-zone heating. The two zones are the seat cushion and backrest; relative heating (balance or distribution) between them is controlled from the iDrive monitor.
- With Comfort seats – 3-stage/4-zone heating, as in the 7 Series. The four zones are the center portions of cushion and backrest and their edge areas. Includes rapid heating: When the heating is first switched on, the center zones heat at full power almost to their regulated heat level; then the outer zones join and all are brought up to the regulated level.
- **Heated steering wheel.** Available for the first time in this Series in combination with the Sport Package.

Also a first in the 5 Series is availability of heated rear seats, as a stand-alone option only in combination with this Package.

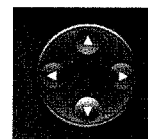

Another new possibility in the new 5: the Sport Package's sport seats can be combined with the power lumbar support that's available in the Premium Package.



New retracting headlight washers are part of the Cold Weather Package.

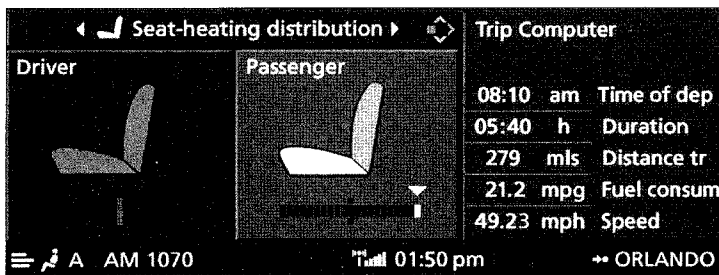

In this view of the iDrive screen, controls for seat-heating distribution and the On-board Computer are seen.

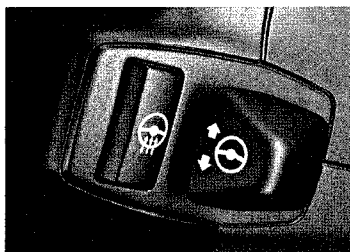

Switch for heated steering wheel is now on the left side of the steering column, next to that for the wheel's tilt/telescopic adjustment.

Premium Sound Package (all models, code OPSP)

Benefits

- Brings audiophile-quality Logic 7 audio system to 5 Series
- Includes new glove-compartment-mounted CD changer

This Package corresponds to that in the 7 Series. The contents are –

Logic 7 audio system.

Upgrades the entire audio system with –

- Increased audio power
- Even higher-caliber speakers throughout, plus additional speakers (total 13 speakers, vs. standard 10)

- Digital Sound Processing (DSP), adjusted along with other Logic 7 parameters on the iDrive monitor
- Surround Sound simulation.

Speakers are as follows; an asterisk (*) denotes additional speakers over the standard system –

- 100-mm midrange fill speaker, center of dash*
- 100-mm midrange in each front door
- 25-mm tweeter in mirror triangle of each front door¹²
- 100-mm midrange in each rear door*
- 100-mm midrange surround speaker at each side of rear shelf
- 25-mm tweeter at each side of rear shelf, inboard of surround speakers
- 210-mm central bass (sub-woofer) in cavities at the bases of the B-pillars (often described as being “under the front seats”). Use of these “sill cavities” is patented by BMW, and enhances audio quality beyond even similar systems in competitive models.

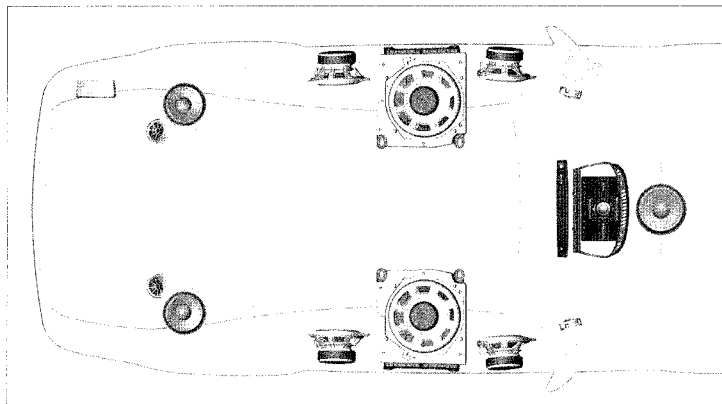

Logic 7 audio system delivers audiophile-quality sound via a digital Surround Sound process, utilizing the 13 speakers depicted here.

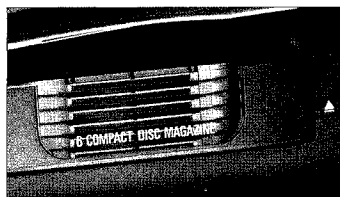

The compact, magazine-type 6-disc CD changer mounts at the forward end of the glove compartment.

voluminous bass that, according to Edgar Kirk (head of BMW's audio department), can power up to 110 decibels.”

6-disc CD changer, mounted at the front end of the glove compartment and taking up no glove-compartment space. It retains a magazine, as opposed to one-disc-at-a-time insertion/ejection of some competitive changers.

6-speed STEPTRONIC automatic transmission (all models, code 205)

Benefits

- BMW's 5-speed automatics were already outstanding; this new transmission is even more so
- Thanks to its 6 speeds, power flow is almost seamless
- STEPTRONIC version in all models

Described on page 16, this advanced, performance-enhancing and velvety-smooth automatic is offered as a stand-alone option on the two 6-cylinder models (525i and 530i), and as part of the 545i model's standard equipment configuration.

Developed by Lexicon, the audio system incorporates an exciting digital Surround Sound process, as in current Harman Kardon home AV receivers. The first of its kind in a motor vehicle and exclusive to Harman International brands, this process provides truly unique and realistic reproduction, generating a 360° sound field and accurately re-creating the acoustic intent of the original studio master. Now to be available in both 7 and 5 Series, the system offers –

- A multi-channel format
- A new benchmark for the automotive industry
- Unparalleled acoustic realism and clarity
- A significant point of differentiation for our customers.

Logic 7's excellence was described by Germany's *auto motor und sport* in its December 12, 2001 issue: “Assuming a multi-channel music source, the orchestra sounds wonderful at windshield level; the public applauds from the rear. Everything is underpinned by powerful,

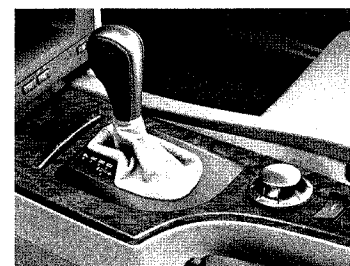

Every model offers a new 6-speed STEPTRONIC automatic transmission.

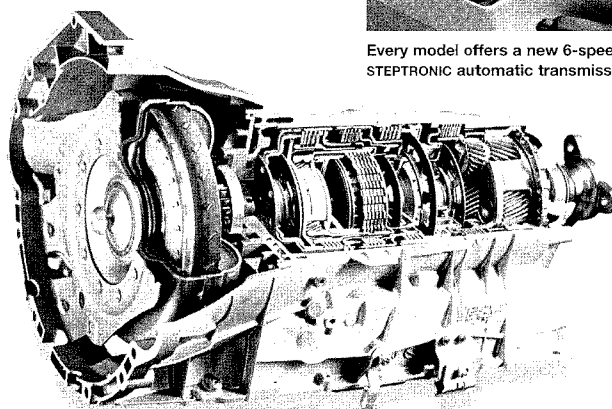

¹² – This is a difference from the 7 Series system, whose tweeters are 44 mm.

Options & accessories

6-speed Sequential Manual Gearbox (SMG)

(all models, requires Sport Package; code 206)

Benefits

- Retains efficiency of manual transmission, yet offers choice of automated or manual shifting
- 6 speeds
- Can shift faster than even an expert driver
- No clutch pedal
- Manual shifting via shift lever or steering-wheel "paddles"

To be offered in the 530i and 545i as of 9/03 production and the 525i as of 3/04 production, the E60's SMG is similar to that offered in the Z4 Series, rather than the BMW M version with Drivelogic. It is described in detail on page 17.

Active Cruise Control

(all models, code 541)

Benefits

- Automatically adjusts vehicle speed to that of slower-moving vehicles ahead
- Driver can choose following distance according to personal preferences
- System can also adjust vehicle speed in curves

Recently introduced on the 7 Series, ACC will be offered as a stand-alone option.

Employing a radar sensor at the front of the vehicle, ACC senses the speed of vehicles traveling ahead, and adjusts the BMW driver's speed to maintain a safe following distance. Operation is as follows:

When the road is clear, operation is essentially as with the standard cruise control, though with certain specific nuances and without the programmable features:

- The current speed is captured by tipping the cruise-control stalk forward or rearward. Thereafter, each time the stalk is tipped forward or rearward, the set speed is increased or decreased by 5 mph.

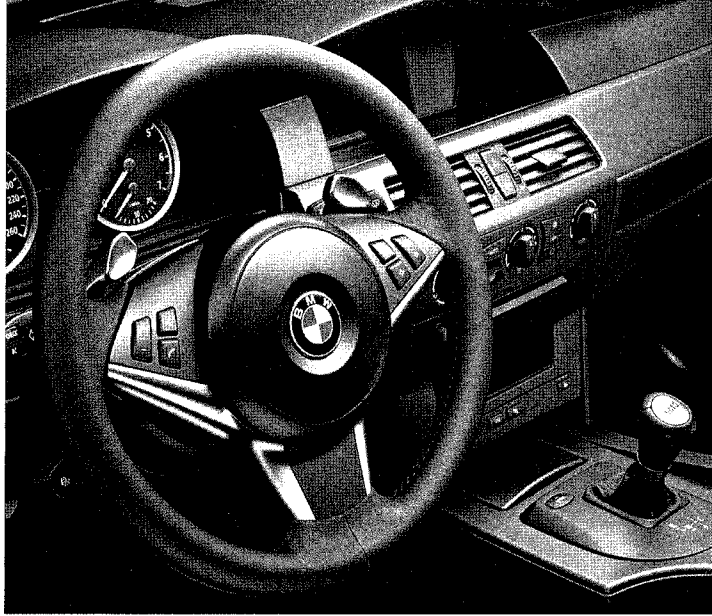

SMG shift paddles are located for an ergonomic thumb's reach from the steering-wheel rim.

- The driver can also adjust the set speed (upward only) in increments of 1 mph by pressing inward on the slider button at the left end of the stalk. When cruise control has been cancelled (by braking, for example), this button is used to resume.
- The set speed is indicated by an arrow at the speedometer scale and a digital display in the instrument's center field.

When traffic is encountered ahead, ACC's special capabilities come into play:

- The driver can choose from four following distances by adjusting the rotary dial on the control stalk. Via four bars below the vehicle icon in the speedometer dial, the chosen following distance is displayed briefly after selection (more bars = greater distance). Logically, ACC also automatically adjusts the following distance according to vehicle speed; this adjustment governs the relative following distance for any given speed.
- When the radar sensor detects a vehicle ahead, the "vehicle" icon in the speedometer dial illuminates. ACC adjusts the BMW driver's speed to maintain the selected following distance.

Active Cruise Control will be available on all automatic-transmission-equipped models from start of production, and in combination with manual and SMG transmissions as of 9/03 production.

enough, in which case the vehicle icon is surrounded by a blinking triangular warning signal indicating that the driver should take evasive action. ACC does not react to stationary vehicles or other objects ahead.

- When traffic ahead clears, ACC automatically resumes the previously set cruising speed.

ACC can also reduce vehicle speed when a curve is entered at too high a speed. However, the system does not "look ahead" to curves, so any such adjustment occurs only after the curve is entered. In sharp curves, ACC may react briefly to oncoming vehicles; the driver can cancel this action by stepping on the accelerator.

ACC is a technologically advanced driving enhancement – meaningful, welcome and stress-reducing, particularly in fast-moving yet congested traffic. The buyer of a vehicle so equipped should be given a careful and thorough explanation of ACC's functions and benefits, and should be advised to study the system's operation.

The capabilities of ACC in no way relieve the driver of the responsibility to devote full attention to driving, to traffic and to all aspects of the driving environment!

- In adjusting vehicle speed, ACC may apply the brakes. It may also apply the brakes when the driver changes the set speed abruptly. If the brake application causes DSC or ABS to activate, a specific warning indicator in the dial face illuminates.
- When a vehicle pulls into the BMW driver's lane, ACC recognizes that vehicle only when it has fully moved into the lane. If the vehicle cuts suddenly into the lane, ACC may not be able to adjust speed quickly

Having made its debut on the 7 Series, Active Cruise Control now comes to the 5 Series as a highly sophisticated option.

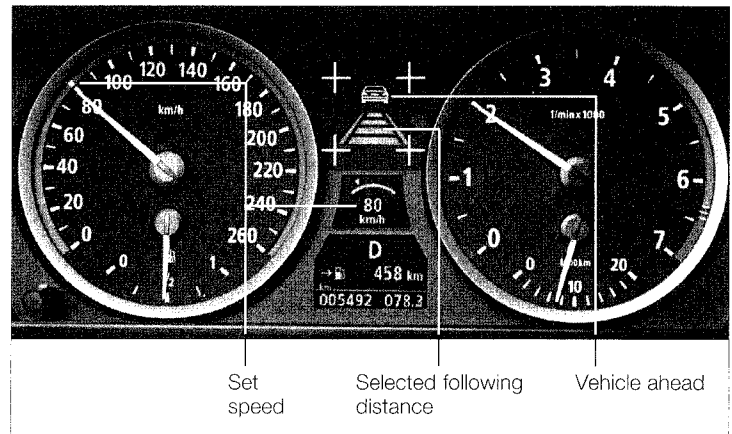
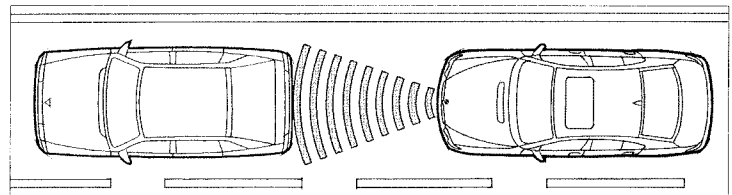

Controls and displays for the Active Cruise Control. Multi-function control stalk provides "coarse" speed settings (+/- 5 mph), adjustment of following distance, cancel, and resume/+1 mph. The set speed is displayed

both digitally and as a mark on the speedometer dial; the set following distance appears graphically, as does an indication of traffic ahead.

Park Distance Control (all models, code 508)

Benefits

- Alerts driver when front or rear of vehicle is approaching an unseen obstacle
- Facilitates parking in tight spaces
- Can help driver conserve parking space

PDC employs four ultrasonic sensors each in the front and rear bumpers to warn the driver when the vehicle is approaching obstacles that may not be visible to the driver. The front sensors cause a higher-pitched tone that emanates from the front of the cabin; the rear ones trigger a lower-pitched tone at the rear.

A significant enhancement relative to the current 5 Series (and shared with the 7 Series) is that when combined with the Navigation System, PDC includes a plan-view vehicle diagram in the iDrive monitor, which graphically and colorfully depicts the obstacle's location relative to the vehicle.

Xenon Adaptive headlights with dynamic auto-leveling (optional 525i & 530i, standard 545i; code 522/524)

Benefits

- Xenon forward illumination now on both low and high beams
- Dynamic auto-leveling helps optimize forward illumination and avoid glare to oncoming drivers
- New Adaptive Light Control helps driver "see around curves"

This new option steps out ahead of the present 5 Series Xenon headlights in two ways:

- Xenon illumination on both low and high beams; currently low beams only
- The Adaptive feature, making its second appearance after a debut on '04 3 Series coupes and convertibles.

BMW pioneered Xenon low-beam headlights with the 1995 7 Series; in the meantime they have become standard on V-8 5 Series, M5 and Z8/ALPINA models and optional on 6-cylinder 5 Series models. The new Xenon lights, with their ultra-bright, daylight-like illumination on both low and high beams, are currently standard on the 7 Series and optional on the 3 and Z4 Series. New Xenon low and high beams come to the 5 Series as well. Here the outboard lamps serve as both low and high beams; the inboard ones function as headlight flashers and Daytime Running Lamps.

Adaptive Light Control (ALC) is a new BMW feature literally "aimed" at making night driving safer. With the headlight switch in its Automatic position, as soon as the vehicle is moving forward (the feature is inactive when the vehicle is stationary or backing up), the outboard lights steer with the front wheels, guided by an electronic control system and swiveled by small servo motors. The system responds not merely to the steering angle, but also to vehicle speed and the "yaw rate," or the rate at which the vehicle's direction is changing. The tangible customer benefit is enhanced night vision around corners and curves, and therefore greater driving safety.

The system includes dynamic auto-leveling of the headlights; headlights' aim is adjusted not only for loads carried in the vehicle, but also in response to even transitory acceleration and braking. Although BMW is first to introduce this feature in the U.S., we won't be alone for long: Expect to see it in the Lexus RX 330, Mercedes-Benz E-Class and Porsche Cayenne for the '04 model year.

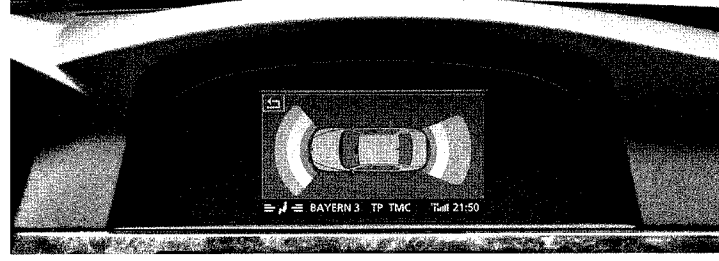

A new feature of Park Distance Control is this plan-view diagram in the iDrive monitor,

which graphically depicts obstacles' location relative to the vehicle.

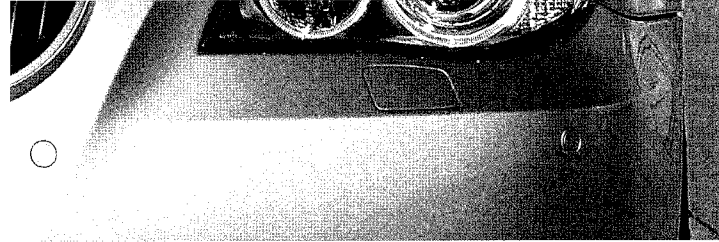

As before, 5 Series Park Distance Control employs four ultrasonic sensors each in the front and rear bumpers to detect objects or

impediments that might be out of the driver's line of sight. Two of the four front PDC sensors are visible in this view.

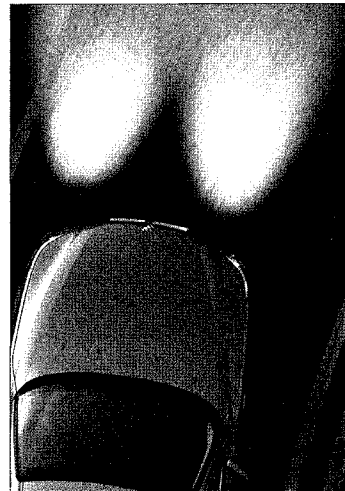

With the headlight switch in its Automatic position, ALC "steers" the Xenon headlights according to steering angle, vehicle speed

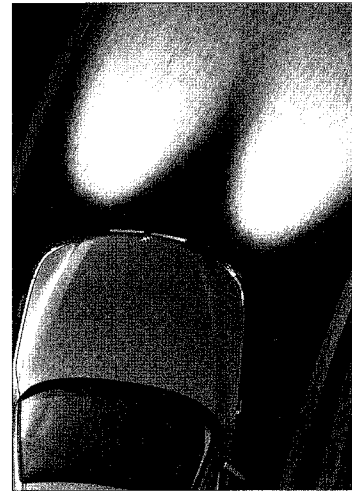

and the rate at which the vehicle's direction is changing.

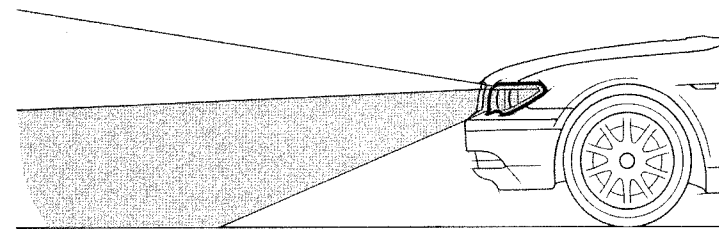

Xenon low and high beams. System includes dynamic auto-leveling of the main lamps.

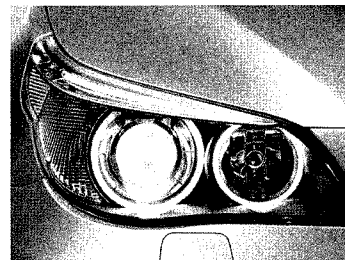

Xenon low- and high-beam headlights replace former low-beam Xenons. Ellipsoid outboard lamps serve as low and high beams; inboard free-form lamps function as headlight flashers and Daytime Running Lamps.



With the optional Head-up Display, selected information can be displayed in a 6 x 3-in. field in the windshield.

Head-up Display

(all models, code 610; requires On-board Navigation System)

Benefits

- Driver can read certain information with minimal diversion of eyes from road ahead
- Brightness of display adjustable by driver; also adjusts automatically to ambient light and moisture conditions
- Can be turned on or off

This exciting new feature makes its debut in the E60, displaying important information in color on a 6 x 3-in. field in the windshield. A virtual image is projected from the top of the instrument panel onto the windshield, appearing approximately in line with the end of the hood in the driver's field of sight. Thus the driver can observe the information displayed here with essentially no diversion from the road ahead. Via the iDrive monitor and controller, the driver decides which information is to be displayed here and the brightness of the display; the Head-up Display can be switched on and off via an additional switch in the lighting control center, left of the steering column.

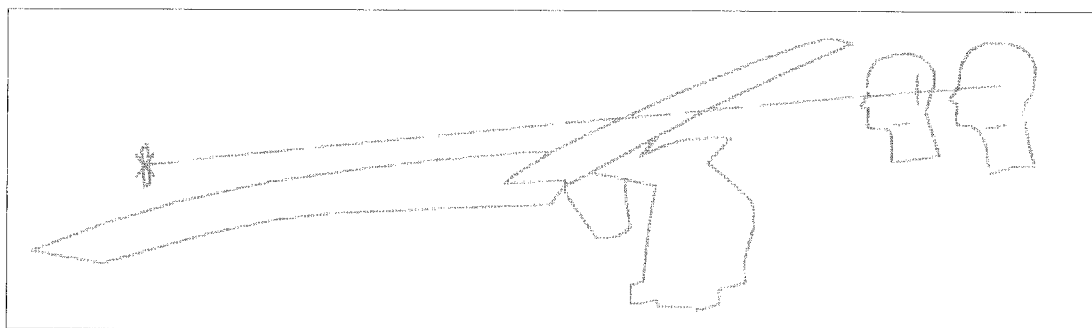

The display appears just below the driver's normal line of sight so that the display can be viewed with minimal diversion from the road ahead.

Information of the following categories can be displayed:

- Check Control and On-board Computer warnings, prioritized according to their urgency, such as vehicle defects, engine-oil level, low windshield-washer fluid
- Navigation instructions
- Active Cruise Control programmed speed.

In addition to the basic brightness selected via the iDrive monitor, the display's brightness is also automatically regulated according to ambient light and moisture conditions via the sensors that govern the automatic headlight control and rain-sensing wipers. Settings chosen by the driver are captured by the Key Memory System and are re-captured when the individual user unlocks the car.

BMW plans to offer this feature as of 9/03 production. On vehicles equipped with it, the green band at the top of the windshield is eliminated.

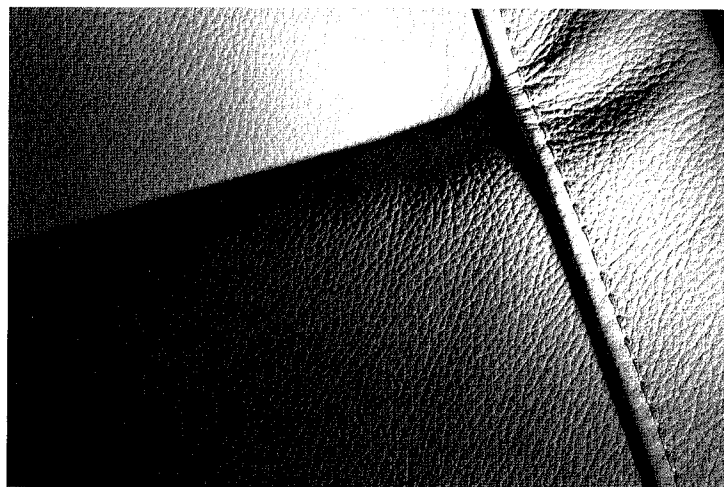

Luxurious new Dakota leather upholstery is available as either part of the Premium Package or a stand-alone option.

Dakota leather upholstery
(optional 525i & 530i, standard 545i; code LC)

Benefit

- Buyer can opt for leather upholstery without the Premium Package

The softer, more luxurious Dakota grade made its debut in the X5 in model year 2002. Available as this stand-alone option or as part of the Premium Package.

Front multi-function Comfort seats

(all models, code 456)

Benefits

- 20-way power adjustment
- Adjustable “wings” on head restraints

Described in detail on pages 34, these seats incorporate 20-way power adjustment and memory for both driver and passenger. In the 525i and 530i, they require leather upholstery (Premium Package or stand-alone option).

4-way power lumbar support for front seats

(545i, code 488)

Benefits

- Adjusts lumbar support for firmness and height
- Now available with sport seats as well as standard seats

This feature, which is part of the 525i and 530i models’ Premium Package, is available as a stand-alone option for 545i models. Here too, it is notable that power lumbar support is available in combination with the sport seats that are standard in the 545i 6-Speed and included in the 545i Sport Package. And it is included in the also optional Comfort seats.



16-way power Comfort front seats were available in the previous 5 Series; now this feature appears in evolved form, with 20-way power adjustment, memory for both driver

and front passenger, and (inset) adjustable “wings” on head restraints. Perforated Nasca leather seen on head restraint is not available in U.S. models.



Once again, split folding rear seats are offered in combination with a center pass-through and ski bag. Instead of having locks on the rear shelf, they are now released from inside the trunk.

Split folding rear seats and ski bag

(all models, code 465)

Benefits

- Enhance versatility of passenger- and cargo-carrying capability
- Allow skis to be carried “indoors”
- For security, folding seats can be unlocked only from inside trunk

The seats are split 60% left/40% right. Instead of being lockable from the inside as before, they are now released from inside the trunk as in the 3 Series. The pass-through for the ski bag is in the center, and thus part of the 60% side; like the standard rear seat, there are three head restraints. Thanks to the new body construction (described on page 35), this arrangement can be retrofitted to existing vehicles with the standard rear seat. Also, differently from the previous 5 Series, this option will be available in combination with the 6-cylinder models’ standard leatherette upholstery.

Heated rear seats

(all models, code 496; require Cold Weather Package)

Benefit

- Cold-weather comfort of heated seats now available for rear-seat passengers

Available only in combination with the Cold Weather Package and leather upholstery, this new option offers 3-stage/2-zone heating of the other seating positions. The heat controls are at the rear of the center console.

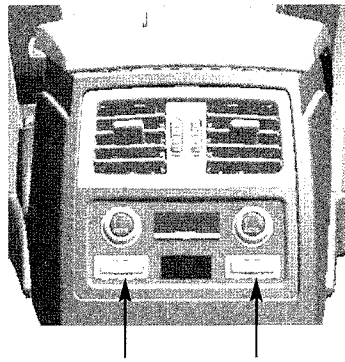

Heated rear seats become available in the 5 Series for the first time; their controls (arrows) are conveniently positioned at the aft end of the center console.

BMW On-board Navigation System

(all models, code 609; delayed availability)

Benefits

- Integrated into iDrive system
- Includes larger, higher-resolution iDrive screen and Force Feedback controller
- Expanded and improved functions
- Includes Voice Command System (see below)

As mentioned earlier, a simplified version of iDrive is standard in all E60 models; vehicles equipped with the optional Navigation System get an iDrive version with a larger (8.8-in.) screen, a controller incorporating Force Feedback (as in the 7 Series), and other distinctive features.

Though the Navigation System is the same in principle as the familiar system currently offered, it offers a number of updates and enhancements. Here's an overview of its functions and features, with explanations of what's new.

Destinations can be input on the basis of –

- Address
- Points of Interest (sightseeing destinations, BMW Centers, etc.)

- Address book (frequently used destinations input by the user)
- Last destination.

Route guidance is given via voice simulation and visual instructions; a new feature is that when the vehicle is equipped with the optional Head-Up Display (HUD), the latter can be projected onto the windshield in the driver's line of sight. In locations where a traffic monitoring system is present, traffic announcements appear as pop-ups on route-guidance screens; announcements not relevant to the current route can also be viewed by the user. When a specific announcement affecting the current route is displayed, the driver can choose to have its information programmed into the route guidance.

Dynamic route planning. Introduced in the 2003 update of the Navigation System, this feature relies on an infrastructural traffic monitoring system. Its purpose is always to choose the best route. If the driver encounters a traffic jam, this is recognized by the system, which evaluates alternative routes. If it decides that the best route is the one with the traffic jam, it guides accordingly. On the other hand, if there are multiple jams, it may completely rework the route so

as to circumvent all of them, not just each one individually. The vehicle's current position (latitude, longitude, even altitude) can be displayed if the user desires.

Estimated time of arrival is calculated with great precision, as the system's data base incorporates road/street categories (freeways, city streets, country roads, etc.) and their speed limits.

Destinations can be entered from the map display as well as alphanumerically in the current manner. It is also possible to "block" certain stretches of road along the way and have the system plan its route around those stretches.

Route guidance is provided by voice and the visual display. When a map is on the monitor, it is accompanied by a display of the map scale and orientation. This means that –

- North is always displayed
- The direction of travel is displayed
- A perspective view is offered.

A new Menu button, just behind the controller, simplifies selection of the main menu. Next to the Menu button is the PTT (Push to Talk) button, which activates the Voice Command System.

Voice Command System (all models, code 620; included with Navigation System)

Benefits

- Convenient voice activation of many functions
- Includes text-to-speech engine
- New interaction of graphics and speech

A Voice Command System became standard in the 7 Series in January '01, and continued into the new 7 Series. Though in production it's logistically a separate option, a significantly updated version of this system is bundled with the Navigation System option for the new 5 Series models.

A major new feature of the system is its **text-to-speech engine**, which makes it possible to translate various text messages, such as radio-station names and (in the future) received e-mails, into voice form. Also new is interaction of graphics and speech: Whereas in the 7 Series these two paths are separate, in the new 5 they work together. For example, the user might select a radio station via Voice Command; the monitor would then display this choice. Once the phone menu is selected (as before, the BMW Onboard Phone System is a Center-installed accessory), one can dial the number of a programmed phone contact by merely speaking his or her name. And it will now be possible to get guidance to a city or town by merely speaking its name.

In summary, Voice Command can put its new and advanced user interface to work controlling the –

- Phone system, including phone book
- Address book
- Navigation System
- Short Message System (SMS)
- BMW Assist
- Audio system
- Climate control.

The system can recognize 3000 words.

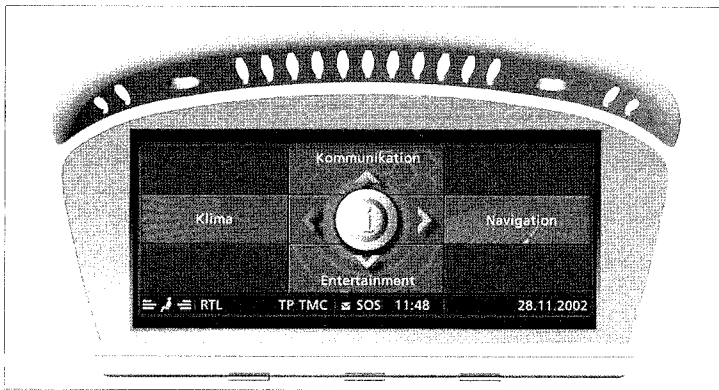

With the optional Navigation System comes this larger (8.8-in.), higher-resolution (640 x 240 pixels) monitor.

This is how Navigation System instructions appear on the iDrive screen (German version).

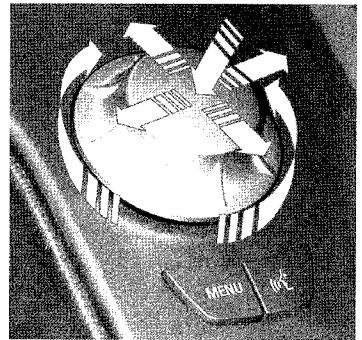
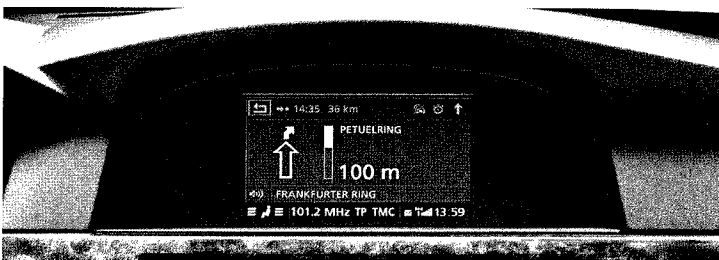

Voice Command is activated by the push-to-talk button positioned behind the controller; controller includes additional motions in GPS Navigation operation.

Sirius Satellite Radio
(all models, code 655)

Benefits

- **Integrated into vehicle audio system**
- **Offers 100 channels of programming**
- **Includes scan and presets**

In a departure from the present strategy of offering Sirius as a Center-installed accessory, all E60s will be available with Sirius as a regular option.

The Sirius system beams programming to satellites orbiting the earth; in turn, Sirius-equipped vehicles receive the programming. Except for locations where reception is physically blocked, users can enjoy the same programs anywhere in the continental United States. Sirius provides 60 original channels of commercial-free music of virtually every genre, and 40 sports, news and entertainment channels.

Sirius hardware for the vehicle consists of –

- an activated Sirius Satellite Receiver
- A Satellite Antenna, incorporated into the shark-fin antenna housing that will be standard on all 5 Series models
- A Sirius-compatible audio system, which is also standard.

Once the equipment is activated, the customer simply selects the satellite radio mode (example: AM/FM/CD/Satellite). As with FM and AM, users are able to scan and set their favorite presets. The audio display can show the channel name, channel number and (in the case of music channels) artists and music title.

Because it has been designed to accommodate an even broader range of technology than that of the 7 Series, the 5 Series' shark-fin antenna is somewhat larger; a recess is stamped into the roof panel for its installation.

Rear-seat Entertainment Package
(all models, code OREP)

Benefits

- **Enables multimedia viewing and listening in the rear seat**
- **Includes remote control, headphone jacks and input jack for external multimedia sources**

To be available as of 3/04 production, this Package will include –

- A video monitor for the rear seat, positioned at the rear of the center console
- A trunk-installed 6-disc multimedia changer (capable of handling CDs and DVDs)

- Two wireless headphones and remote control
- An input jack for external sources.

The 6.5-in. color monitor offers all menus available on the front monitor, unless they are blocked from the iDrive system in front. It is controlled by a wireless remote, which is subordinate to the front controller. At the aft end of the console there are two headphone jacks, as well as the input jack for external sources such as Gameboy, MP3 player or a VCR.

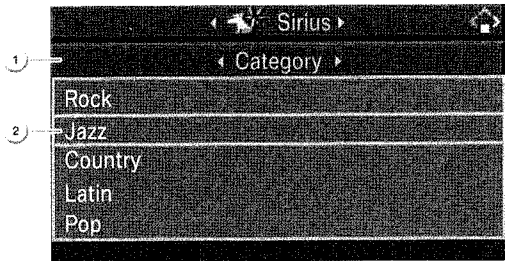

Sirius screen in the iDrive monitor:
1 - User can scroll through the many program categories by rotating the controller, then pressing the controller to go to the category list.
2 - In the list, the user again scrolls and presses to select the program type.

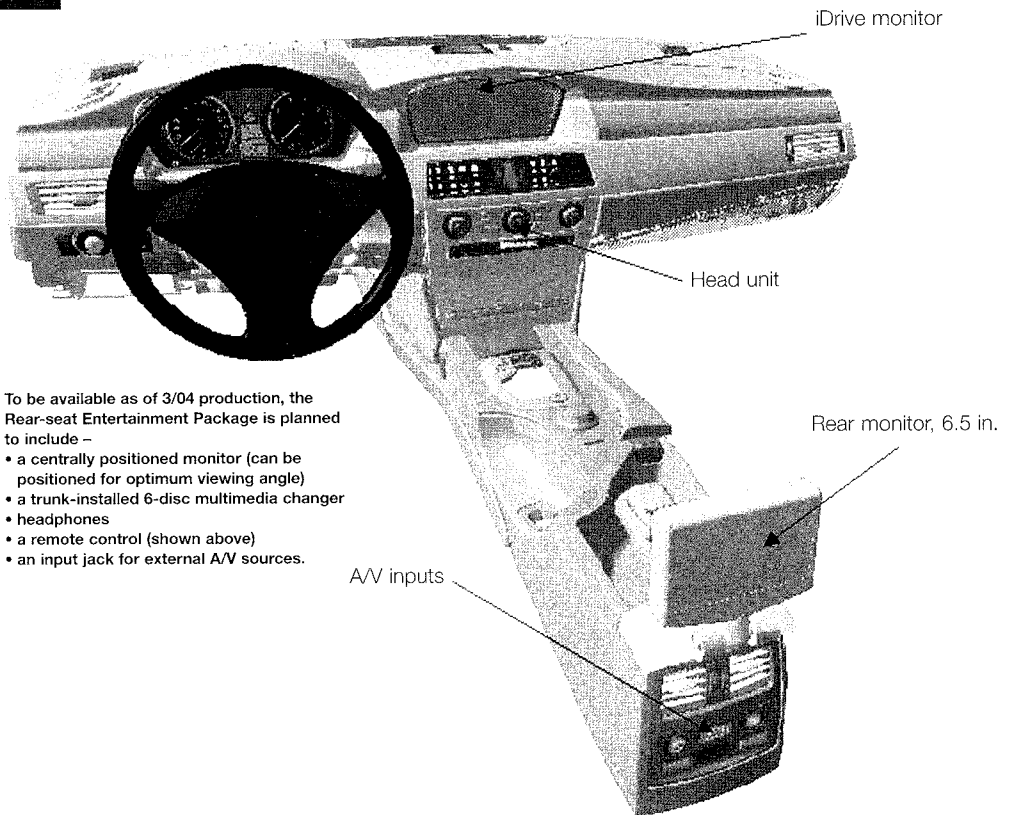
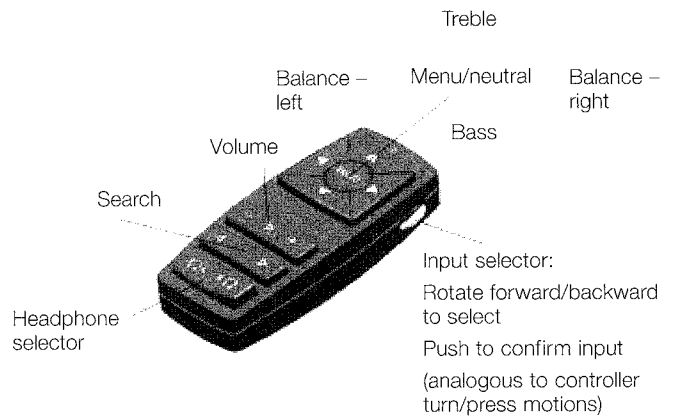

To be available as of 3/04 production, the Rear-seat Entertainment Package is planned to include –

- a centrally positioned monitor (can be positioned for optimum viewing angle)
- a trunk-installed 6-disc multimedia changer
- headphones
- a remote control (shown above)
- an input jack for external A/V sources.

Power rear sunshade and manual rear side-window sunshades

(all models, code 416)

Benefits

- Reduce glare and external heat load for rear-seat passengers
- Add privacy
- Driver can operate power rear-window shade

This elegant and useful option continues, but with improvements. As before, the rear-window shade is powered, and controlled from a console switch. Where the previous 5 Series had a single side shade for each main, openable rear-door window, the new Series provides shades for the main window (opening vertically) and the fixed quarter pane (opening radially). These are manually (and easily) opened or closed by the rear-seat passengers.

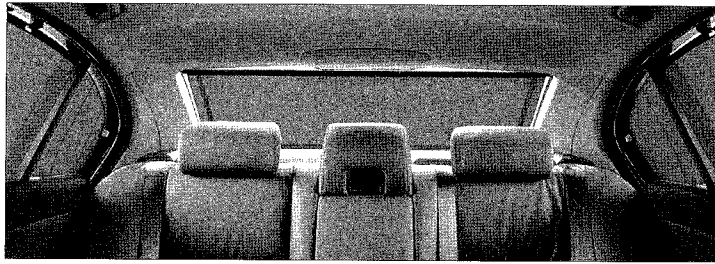

Optional rear sunshades include power rear-window shades as before, plus new 2-segment manual rear side-window shades.

Maple Anthracite wood interior trim

(available as described, all models; code 435)

Benefits

- Two choices of wood trim
- Maple Anthracite is an especially distinctive new alternative

Dark Poplar wood trim is standard in the 545i, and included in the 525i/530i Premium Package. As a no-extra-cost option for any 545i and Premium-Package-equipped 525i/530i models,

Maple Anthracite is available. With its gray color and "striped" grain, Maple Anthracite is especially distinctive and contemporary, and harmonizes well with all interior colors. The wood trim appears on the instrument panel and center console.

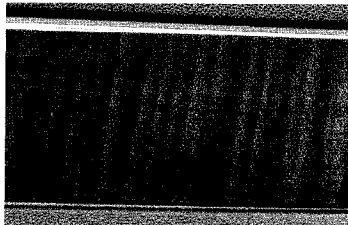

Maple Anthracite wood trim is available as a no-extra-cost option for 525i and 535i models with the Premium Package, and for any 545i.

BMW Center-installed accessories

BMW Cellular Phone System
(all models)

Benefit

- New communications technologies to be offered

BMW Cellular Phone Systems are undergoing a significant evolution as the new 5 enters production. It will be possible to equip vehicles with a cradle that accommodates any Motorola V60c phone, or to acquire a BMW-specific version of the V60c, called CPT 9000. Vehicles are pre-wired for the CPT 9000 at start of production; the new pre-wiring requires less installation work (and lower installation cost) than before; essentially only the eject box (cradle) must be added.

A Bluetooth interface that accommodates any hand-held cell phone will become available later; this is planned for 3/04 production. Installation will be similarly simplified.

Rear-seat side-impact airbags

(all models, code 261)

Benefits

- Side-impact protection for rear-seat passengers
- Offered as option so that customers can decide whether or not to order

Per established BMW policy, rear-seat side-impact airbags remain optional. For the first time in the 5 Series, this option also includes automatic tensioners on the rear outboard safety belts (a feature that is included in the 7 Series' rear Comfort Seats).

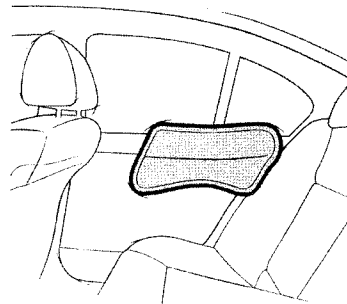

Per established BMW policy, rear-seat side-impact airbags remain optional.

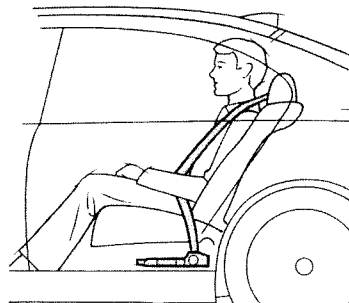

Newly included in option 261 are automatic tensioners for the outboard rear safety belts.

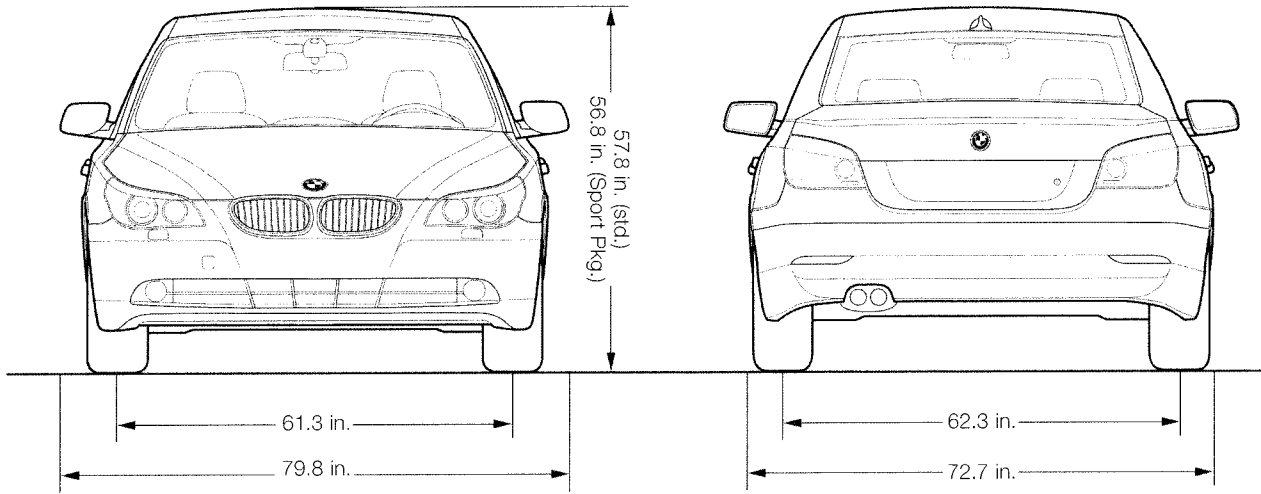

The new 5 Series: Features & specifications

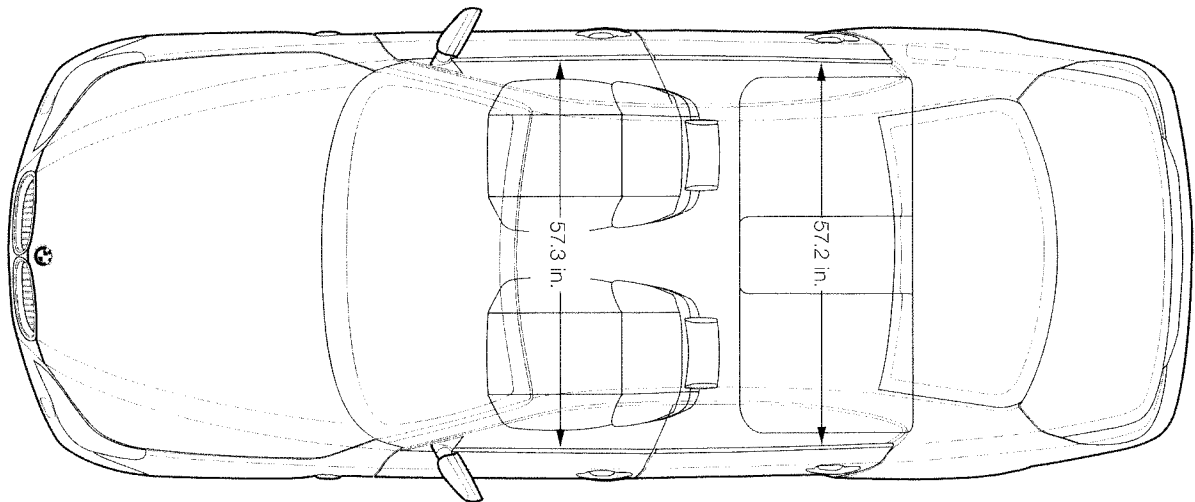
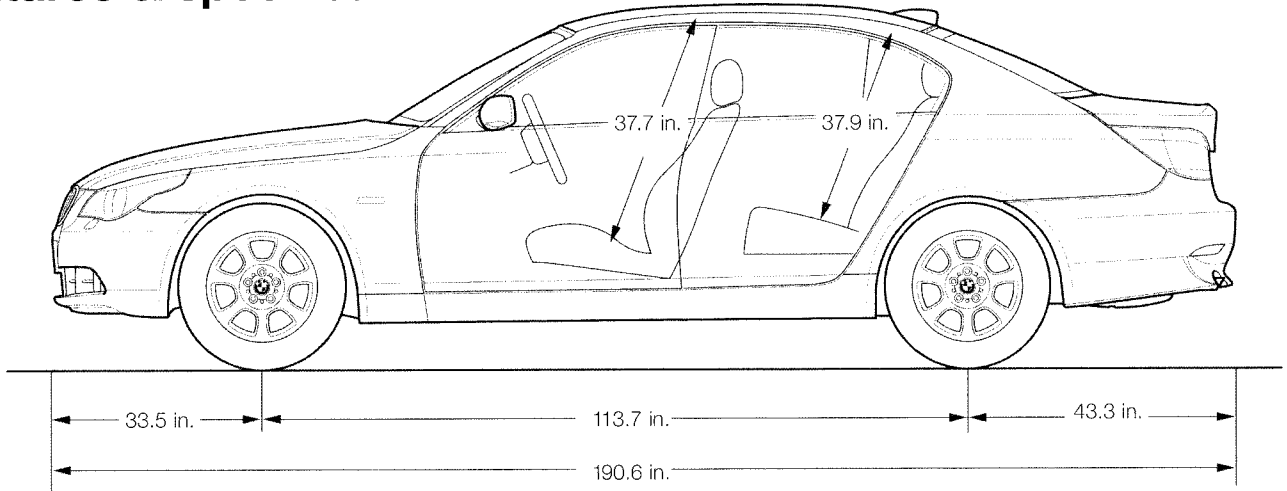

Standard & optional features

2004 5 Series

Bold indicates new feature relative to corresponding 2003 5 Series model.

Performance & efficiency	525i	530i	545i	545i 6-Spd
DOHC 24-valve inline 6-cylinder engine with Double VANOS ¹ steplessly variable valve timing:				
2.5-liter	S	-	-	-
3.0-liter	-	S	-	-
4.4-liter DOHC (4-cam) 32-valve V-8 engine	-	-	S	S
Engine features:				
Aluminum block & cylinder head(s)	S	S	S	S
Valvetronic system	-	-	S	S
Dual resonance intake system	S	S	-	-
Steplessly variable intake system	-	-	S	S
Electronically controlled engine cooling (map cooling)	S	S	S	S
Direct ignition system with knock control	S	S	S	S
Liquid-cooled alternator	-	-	S	S
6-speed manual transmission	S	S	-	S
6-speed STEPTRONIC automatic transmission with Sport & Manual shift modes	OPT	OPT	S	NA
6-speed Sequential Manual Gearbox (SMG) with Automated, Manual & Sport programs ²	OPT	OPT	-	OPT

Handling, ride & braking	525i	530i	545i	545i 6-Spd
Aluminum double-pivot-type front suspension	S	S	S	S
Aluminum 4-link Integral rear suspension	S	S	S	S
Front & rear anti-roll (stabilizer) bars	S	S	-	S
Aluminum front & rear subframes	S	S	S⁴	S⁴
Twin-tube gas-pressure shock absorbers	S	S	S	S
Sport suspension calibration	OZSP	OZSP	OZSP	S
Active Roll Stabilization (ARS)	OZSP	OZSP	OZSP	S
Engine-speed-sensitive variable-assist, variable-ratio power steering	S	S	S	-
Active Steering with Servotronic power assist	OZSP	OZSP	OZSP	S
4-wheel ventilated disc brakes	S	S	S	S
Dynamic Stability Control (DSC), including Dynamic Traction Control , electronic brake proportioning, antilock braking (ABS), Dynamic Brake Control & cornering/braking stability enhancement	S	S	S	S
16 x 7.0 Trapezoid lightweight forged-alloy wheels (design #134)	S	-	-	-
17 x 7.5 Star Spoke cast-alloy wheels (design #138)	NA	S	-	-
17 x 7.5 Star Spoke cast-alloy wheels (design #116)	NA	NA	S	-
17 x 8.0 Star Spoke cast-alloy wheels (design #122)	OZSP	-	-	-
18 x 8.0 Star Spoke cast-alloy wheels (design #123)	NA	OZSP	-	-
18 x 8.0 front/18 x 9.0 rear Star Spoke cast-alloy wheels (design #124)	NA	NA	OZSP	S
225/55R-16 V-rated all-season tires	S	-	-	-
225/50R-17 V-rated all-season tires	NA	S	S	-
245/45R-17 W-rated run-flat performance tires	OZSP	-	-	-
245/40R-18 W-rated run-flat performance tires	NA	OZSP	-	-
245/40R-18 front / 275/35R-18 rear W-rated run-flat performance tires	NA	NA	OZSP	S
Flat Tire Monitor	S	S	S	S

Exterior & aerodynamics	525i	530i	545i	545i 6-Spd
Front & rear body-color bumpers	S	S	S	S
Halogen free-form headlights	S	S	S	S
Xenon Adaptive headlights with dynamic auto-leveling ⁵	OPT	OPT	S	S
Automatic headlight control	S	S	S	S
High-intensity headlight cleaning system	OZCW	OZCW	OZCW	OZCW
Daytime Running Lamps	S ⁶	S ⁶	S ⁶	S ⁶
Halogen free-form foglights	S	S	S	S
Park Distance Control (front & rear) with graphic display	OPT	OPT	OPT	OPT
Rain-sensing windshield wipers with articulated passenger-side wiper arm, adjustable & car-speed-sensitive wiping interval, single-wipe control, windshield-washer system with heated washer jets	S	S	S	S
Heated exterior mirrors	S	S	S	S
Choice of standard or metallic paint	NC	NC	NC	NC
Shadowline exterior trim	OZSP	OZSP	OZSP	OZSP
Adaptive brakelights	S	S	S	S

Ergonomics, luxury & convenience	525i	530i	545i	545i 6-Spd
Vehicle & Key Memory	S	S	S	S
Keyless entry with multi-function remote control	S	S	S	S
Selective unlocking	S ⁷	S ⁷	S ⁷	S ⁷
Remote trunk release	S	S	S	S
Dual power/heated exterior mirrors	S	S	S	S
Automatic tilt-down of right exterior mirror for visibility of curb when backing up	S	S	S	S
Automatic-dimming inside & exterior mirrors	OZPP	OZPP	OPT	OPT
BMW Universal Transceiver (garage-door opener)	OZPP	OZPP	S	S
Courtesy lights with fade-in/fade-out feature, actuation from remote, automatic switch-on when engine is turned off	S	S	S	S
Front & rear reading lights, separately controlled left/right	S	S	S	S
BMW Ambiance Lighting	S	S	S	S
Design Light Package (upgraded exterior/interior & Ambiance Lighting)	OZPP	OZPP	S	S
Lockable glove compartment with rechargeable take-out flashlight	S	S	S	S
Power tilt/telescopic leather-wrapped steering wheel with fingertip cruise, audio & phone ⁷ controls, automatic tilt-up for entry & exit: Standard, 385 mm/3 spokes	S	S	S	S
Heated	OZCW	OZCW	OZCW	OZCW
Cruise control	S	S	S	S
Active Cruise Control⁸	OPT	OPT	OPT	OPT
10-way power front seats with power head restraints	S	S	S	S
12-way power front sport seats with adjustable thigh support	OZSP	OZSP	OZSP	OZSP
4-way power lumbar support, both front seats	OZPP	OZPP	OPT	OPT
20-way power multi-function Comfort front seats , including articulated upper backrests & backrest width, 4-way lumbar support, passenger's-seat memory, & active head restraints with adjustable side support	OPT⁹	OPT⁹	OPT	OPT
Memory system for driver's seat, steering wheel & exterior mirrors (2 settings per user)	S	S	S	S
3-stage heated front seats ¹⁰	OZCW	OZCW	OZCW	OZCW
3-stage heated rear seats	OPT¹¹	OPT¹¹	OPT¹¹	OPT¹¹

Ergonomics, luxury & convenience (cont.)	525i	530i	545i	545i 6-Spd
Adjustable front center armrest	S	S	S	S
Dual center console compartments with provision for phone handset, climate-controlled lower compartment	S	S	S	S
Electronic analog speedometer & tachometer	S	S	S	S
LCD main & trip odometers	S	S	S	S
Expanded Check Control vehicle monitor system	S	S	S	S
Head-up Display (HUD)	OPT¹²	OPT¹²	OPT¹²	OPT¹²
iDrive system with four menus & controller (includes Trip Computer)	S	S	S	S
BMW On-board Navigation System, encompassing expanded iDrive system, controller with force feedback, Voice Command System (includes expanded Trip Computer functions, automatic ventilation system & other features)	OPT¹³	OPT¹³	OPT¹³	OPT¹³
Telematics	S	S	S	S
Leatherette upholstery & color-keyed high-gloss interior trim	S	S	-	-
Dakota leather upholstery (seating & doors)	OPT/ OZPP	OPT/ OZPP	S	S
Dark Poplar wood interior trim	OZPP	OZPP	S	S
Maple Anthracite wood interior trim	NC ¹⁴	NC ¹⁴	NC	NC
Titanium II interior trim (door pulls & interior door handles)	S	S	S	S
Power windows with key-off operation; 1-touch opening & closing of all windows, anti-trapping feature, opening from remote, closing from exterior lock	S	S	S	S
Automatic climate control with separate left/right temperature & air distribution, automatic recirculation control, humidity control, bi-directional solar sensor & other features	S	S	S	S
Activated-charcoal microfilter ventilation	S	S	S	S
2-way power moonroof with expanded 1-touch opening & closing, anti-trapping feature, opening from remote, & closing from exterior lock, sliding interior sunshade	S	S	S	S
Anti-theft AM/FM/CD audio system with 10 speakers, including 2 subwoofers , Radio Data System (RDS) & FM diversity antenna system	S	S	S	S
Logic 7 audio system with 13 speakers, Digital Sound Processing, Surround Sound simulation & 6-disc CD changer in glove compartment; includes 2 subwoofers, upgraded componentry throughout & all features of standard system	OZPS	OZPS	OZPS	OZPS
Sirius Satellite Radio	OPT	OPT	OPT	OPT
Rear-seat video monitor, 6-disc multimedia changer, headphones, remote control & input jack for external sources	OREP¹⁵	OREP¹⁵	OREP¹⁵	OREP¹⁵
Pre-wiring for installation of CD changer with standard audio	S	S	S	S
6-disc CD changer in glove compartment	C	C	C	C
Pre-wiring for BMW Cellular Phone System	S	S	S	S
BMW Cellular Phone System	S	S	S	S
Power outlets in front passenger's footwell, aft end of center console, & trunk	S	S	S	S
Dual cupholders front & rear	S	S	S	S
Dual front sun visors with illuminated mirrors	S	S	S	S
Open storage compartments in front & rear doors	S	S	S	S

Ergonomics, luxury & convenience (cont.)	525i	530i	545i	545i 6-Spd
Fold-up rear center armrest	S	S	S	S
Seatback storage compartments	S	S	S	S
Split folding rear seats & ski bag	OPT	OPT	OPT	OPT
Power-operated rear-window sunshade & manual rear side-window sunshades (2 shade sections per door)	OPT	OPT	OPT	OPT
Rear-window defroster	S	S	S	S
Interior trunk release, electrically operated	S	S	S	S
Fully finished trunk with drop-down toolkit	S	S	S	S

Safety & security	525i	530i	545i	545i 6-Spd
Dual front-impact airbag Supplementary Restraint System (SRS) with dual-threshold deployment, 2-stage Smart Airbags	S	S	S	S
3-point safety belts at all seating positions	S	S	S	S
Front safety belts with automatic tensioners & force limiters	S	S	S	S
Automatic-locking retractors (ALR) on all passenger safety belts (for installation of child restraint seats)	S	S	S	S
Interlocking door anchoring system for side impacts	S	S	S	S
Front- & rear-seat Head Protection System (AHPS II)	S	S	S	S
Front-seat side-impact airbags	S	S	S	S
Rear-seat side-impact airbags & automatic tensioners on rear outboard safety belts	OPT	OPT	OPT	OPT
Active front head restraints	OPT¹⁶	OPT¹⁶	OPT¹⁶	OPT¹⁶
Intelligent Safety and Information System (ISIS) for deployment of safety systems	S	S	S	S
Post-impact safety measures:				
Unlocking of central locking system	S	S	S	S
Switch-on of hazard flashers	S	S	S	S
Switch-on of interior lighting	S	S	S	S
Disconnect of alternator, fuel pump & starter from battery (via Battery Safety Terminal)	S	S	S	S
Central locking system with double-lock anti-theft feature, selective unlocking	S	S	S	S
Coded Driveaway Protection	S	S	S	S
Alarm system with operation from remote, interior motion detector	S	S	S	S

1 - VANOS = VAriable NOckenwellen Steuerung = variable camshaft control, or variable valve timing.
2 - STEPTRONIC is new to V-8 model as standard equipment; formerly only with Sport Package.
3 - Requires Sport Package; available as of 9/03 production on 530i & 545i, 3/04 production on 525i. Includes Dynamic Driving Control.
4 - Aluminum front subframe is new on 545i models.
5 - Xenon low-beam headlights with dynamic auto-leveling were standard on 540i models, optional on 525i & 530i models in 2003.
6 - Selectable via Vehicle Memory System.
7 - BMW Cellular Phone System available as Center-installed accessory.
8 - Available with automatic transmission from start of production, with manual transmission or SMG as of 9/03.
9 - Require leather upholstery (Premium Package or stand-alone option).
10 - Features depend upon which front seats vehicle is equipped with (Comfort seats add features).
11 - Require Cold Weather Package.
12 - Requires On-board Navigation System; available as of 9/03 production.
13 - Delayed availability.
14 - Requires Premium Package.
15 - Planned for 3/04 availability.
16 - Included with optional multi-function Comfort front seats.
S - Standard
OPT - Optional
NC - No extra cost
C - BMW Center-installed
- - - Not applicable
NA - Not available
OZCW - Cold Weather Package
OZPP - Premium Package
OZSP - Sport Package
OZPS - Premium Sound Package
OREP - Rear-seat Entertainment Package

Technical specifications

2004 5 Series

Except for 6-cylinder engines, virtually all specifications are new relative to 2003 5 Series models.

General	525i	530i	545i
Curb weight, lb.: ¹			
Manual transmission	3428	3472	3803
Sequential Manual Gearbox (SMG)	3450	3494	3814
Automatic transmission	3450	3494	3814
Weight distribution, front/rear, %: ¹			
Manual transmission	49.8/50.2	50.2/49.8	50.3/49.7
Sequential Manual Gearbox (SMG)	50.2/49.8	51.1/48.9	51.4/48.6
Automatic transmission	50.2/49.8	51.1/48.9	51.4/48.6
Wheelbase, in.	113.7 ²		
Track, front/rear, in.	61.3/62.3 ^{2,3}		
Length, in.	190.6 ²		
Width, in.	72.7 ²		
Height, in.	58.0 ²		

Body	525i	530i	545i
Type	4-door sedan ²		
Aerodynamic drag coefficient	0.29 ²		
EPA size classification	Compact ^{1,2}		

Accommodations	525i	530i	545i
Seating capacity, persons	5 ²		
Shoulder room, front/rear, in.	57.3/57.2 ²		
Head room, front/rear, in.:			
without moonroof	39.1/38.1 ²		
with moonroof	37.7/37.9 ²		
Leg room, front/rear, in.	41.5/36.0 ²		
EPA interior volume, cu ft.	99.1		
EPA cargo volume, cu ft.	14.0		

Engine & electrical	525i	530i	545i
Engine type	DOHC inline 24-valve 6-cylinder, Double VANOS ⁴ steplessly variable intake- & exhaust-valve timing ⁵		DOHC 32-valve (4-cam) V-8, Valvetronic variable valve lift & Double VANOS ⁴ steplessly variable intake- & exhaust-valve timing
Bore x stroke, mm/in.	84.0 x 75.0/ 3.31 x 2.95	84.0 x 89.6/ 3.31 x 3.53	92.0 x 82.7/ 3.50 x 3.15
Displacement, cc/cu in.	2494/152	2979/182	4398/268
Compression ratio	10.5:1	10.2:1	10.5:1
Power @ rpm, hp	184 @ 6000	225 @ 5900	325 @ 6100
Torque @ rpm, lb.-ft.	175 @ 3500	214 @ 3500	330 @ 3600
Engine-management system	Siemens MS 45 ⁵		Motronic ME9
Fuel requirement	Premium unleaded ²		
Fuel capacity, U.S. gal.	18.5		
Battery capacity, amp-hr.	80 ⁵		90
Alternator output, amp./W	120/1680 ⁵		170/2380

Drivetrain	525i	530i	545i
Drive system	Front engine/rear drive ²		
Manual transmission	ZF Type H, 6-speed ⁵		ZF Type G, 6-speed
Ratios: 1st	4.35:1 ⁵		4.06:1
2nd	2.50:1 ⁵		2.40:1
3rd	1.66:1 ⁵		1.58:1
4th	1.23:1 ⁵		1.19:1
5th	1.00:1 ⁵		1.00:1
6th	0.85:1 ⁵		0.87:1
Reverse	3.93:1 ⁵		3.77:1
Final drive ratio	3.15:1	2.93:1	2.93:1
Sequential Manual Gearbox (SMG)	Electrohydraulic/electronic controls applied to 6-speed manual transmission, ratios as for Type H or Type G as appropriate to model; includes Dynamic Driving Control (Sport button) affecting shift characteristics & engine response to accelerator pedal		
Automatic transmission	ZF 6 HP 19	ZF 6 HP 26	
	6-speed STEPTRONIC with Adaptive Transmission Control, selectable Manual & Sport modes ²		
Ratios: 1st	4.17:1 ²		
2nd	2.34:1 ²		
3rd	1.52:1 ²		
4th	1.14:1 ²		
5th	0.87:1 ²		
6th	0.69:1 ²		
Final drive ratio	3.73:1	3.46:1	3.38:1

Chassis	525i	530i	545i
Body/frame construction	Unitized; aluminum front end, otherwise steel		
Front suspension	Struts, double-pivot lower arms, coil springs, twin-tube gas-pressure shock absorbers, anti-roll bar; aluminum suspension system & subframe (OZSP: sport suspension calibration, Active Roll Stabilization) ²		
Rear suspension	4-link Integral suspension, coil springs, twin-tube gas-pressure shock absorbers, anti-roll bar; aluminum suspension system & subframe (OZSP: sport suspension calibration, Active Roll Stabilization) ²		
Steering type	Rack & pinion, engine-speed-sensitive power assist ² (OZSP: Active Steering with Servotronic vehicle-speed-sensitive power assist)		
Overall ratio, standard steering	Mechanically variable; mean ratio is 14.1:1 ²		
Overall ratio, Active Steering	Electrically/electronically variable over wide range of 10:1 – 18:1 ²		
Turning circle, ft.	37.5 ²		
4-wheel ventilated disc brakes with aluminum calipers:			
Front, diameter x thickness, mm/in.	310 x 24/ 12.2 x 0.94	324 x 30/ 12.8 x 1.18	348 x 30/ 13.7 x 1.18
Rear, diameter x thickness, mm/in.	320 x 20/ 12.6 x 0.79	320 x 20/ 12.6 x 0.79	345 x 24/ 13.6 x 0.94
Assist	Vacuum ²		

Chassis (cont.)		525i	530i	545i	Performance data	525i	530i	545i
Wheels: standard	Lightweight forged alloy, 16 x 7.0	Cast alloy, 17 x 7.5	Cast alloy, 17 x 7.5	Acceleration, 0-60 mph, sec.: ^{1,6} manual transmission or SMG	7.8	6.6	5.7	
	optional (OZSP)	Cast alloy, 17 x 8.0	Cast alloy, 18 x 8.0		automatic transmission	8.2	6.9	5.8
Tires: standard	225/55R-16 V-rated all-season	225/50R-17 V-rated all-season	225/50R-17 V-rated all-season	Top speed, mph ⁷ : manual transmission or SMG	146	150	150	
	optional (OZSP)	245/45R-17 W-rated run-flat performance	245/40R-18 W-rated run-flat performance		automatic transmission	144	150	150
Stability-enhancement system	Dynamic Stability Control (DSC), including Dynamic Traction Control, electronic brake proportioning, antilock braking (ABS), Dynamic Brake Control & cornering/braking stability enhancement ²			Fuel economy, EPA est. MPG, city/highway	TBD	TBD	TBD	

¹ - Preliminary data.
² - Specification applies to all models.
³ - With standard wheels.
⁴ - VANOS = VAriable NOckenwellen Steuerung = variable camshaft control, or variable valve timing.
⁵ - Specification applies to 525i & 530i.
⁶ - BMW AG test results. Actual acceleration results may vary depending on specification of vehicle; road and environmental conditions; testing procedures and driving style. These results should be used for comparison only, and verification should not be attempted on public roads. BMW urges you to obey all posted speed limits and to please wear your safety belt at all times.
⁷ - Electronically limited.
OZSP - Sport Package
F - Front
R - Rear
TBD - To be determined.

Exterior/interior color combinations

2004 E60 5 Series

	Exterior colors											
	Standard colors		Metallic colors									
	Alpine White 300	Jet Black 668	Copper A06 ¹	Mystic Blue A07	Silver Gray A08	Amethyst Gray A09	Olivine Green 349	Titanium Silver 354	Oxford Green 430	Black Sapphire 482	Toledo Blue 482	Titanium Gray 892
Leatherette												
Beige KBBA	●	●	●	●		●	●		●	●	●	
Black KBSW	●	●	●	●	●	●	●	●	●	●	●	●
Dakota leather												
Gray LCAD	●	●		●	●	●	●	●	●	●	●	●
Beige LCBA	●	●	●	●		●	●		●	●	●	
Auburn LCRK	●	●	●	●		●	●		●	●	●	
Black LCSW	●	●	●	●	●	●	●	●	●	●	●	●

¹ - Delayed availability.



Market outlook

As the latest in a long evolution of BMW's "middle" line, the new, 5th-generation 5 Series has a solid foundation for success. And yet past success, such as the steadily growing reputation of four 5 Series generations, is not enough in our fast-paced, fast-changing world. Instead, the new generation must itself be a formula for tomorrow's success. Nor is even that enough: Given a fine new product, which of course BMW always creates, we at BMW must

market it intelligently, communicate effectively its unique combination of established and new qualities, position it credibly and price it for both competitive appeal and corporate profitability.

This section presents an overview of the new 5 Series' market heritage, positioning, competitive field and targeted customer demographics, plus information on its launch program.

Here's what a new 5 Series "automatically" has going for it as it arrives to replace the previous (1997-2003) 5 Series:

Recent heritage. The current, 4th-generation E39 5 Series has been able to keep its sales momentum even in the late stages of its life cycle, actually selling more units in the U.S. during calendar 2002 than in '01. In its most recent full month on the market, May '03, the 5 Series not only remained securely in 2nd place among the various BMW Series, but outperformed its May '02 sales 4,491 vs. 3,849 units – and stayed solidly ahead of key competitors like the Audi A6, Jaguar S-Type, Lexus GS and Volvo S80.

Critical recognition. Throughout the E39's career, the awards have just kept coming. For samplings of the more recent awards and comparison-test wins rung up by the 5 Series, see Fast Facts 2003-2004, pages 12 and 98-99.

A performance edge. The previous 540i was the only V-8 engine/manual-transmission combination in its class, giving the 5 Series a performance edge even over more recently introduced, nominally more powerful competitors.

A roadability edge. As documented again and again in independent reports and tests, the 5 Series' combination of nimble handling and supple riding comfort has remained a unique quality, universally praised by media critics and always appreciated by 5 Series owners.

Positioning the new 5 Series

The positioning statement is –

Engineered for an extraordinary driving experience. In any situation, the perfect synthesis of dynamics, roominess and style.

– whereby the word "dynamics" essentially equates to "power and handling" for our partners in communicating our products.

The 5 Series' competitive field: a growing segment

According to J.D. Power and Associates, the 5 Series Sedans compete in the Mid-Luxury



The E39 5 Series had an enviable market position because of what it was: the "perfectly balanced vehicle." It was widely recognized as such, by owners and critics alike.

segment; its competitors include the Acura RL, Audi A6, Infiniti M45, Jaguar S-Type, Lexus GS, Lincoln LS, Mercedes-Benz E-Class, Saab 9-5 and Volvo S80. Its truly key competitors can be considered to be the –

- Audi A6
- Infiniti M45
- Jaguar S-Type
- Lexus GS
- Lincoln LS
- Mercedes-Benz E-Class
- Volvo S80.

The 5 Series reached its maximum market share in its segment in 1997; since then, even though its actual unit sales continued to increase, the entry of new competitors into the segment (Jaguar S-Type, Lincoln LS and a much stronger Lexus GS than the original) increased overall volume in the segment. Yet over this period, BMW's 5% decline in segment market share was less than that for Volvo (7%) and especially Mercedes-Benz (12%). Calendar-year sales numbers for the segment peaked in 2001, fell back in 2002 and are expected to end 2003 with a further numerical falloff. Much of this segment decline has been attributable to growth in the Luxury SUV category, where



Despite having more variations than the 5 Series, Audi's A6 series achieved only about 60% of 5 Series sales in calendar

2002. But this is no reason for complacency: Industry media report that Audi is laying ambitious plans to increase its volume.

BMW strongly participates in the growth; indeed, 5 Series and X5 volume were neck-and-neck in calendar '02. Sport Wagons joined the 5 Series Sedans in the 1999 model year, contributing to a U.S. sales increase from 35,100 units in calendar '98 to 38,218 in '99. 5 Series volume then moved on to 39,703 in 2000; 40,005 in '01; and 40,842 in '02. As most of the segment's growth had been occurring below what was BMW's entry position up to then, the 525i Sedan and Sport Wagon were added in '01 to help give the Series lower entry price points and thus sustain its volume growth.

At its debut, the new 5 appears in Sedan form only; like the Sedans, E39 Sport Wagons will end production in June '03. With a model-for-model continuation of the previous Sedan positions from 525i and 530i (2.5- and 3.0-liter 6-cylinder) to 545i (4.4-liter V-8, in manual- and automatic-transmission versions and now the Sequential Manual Gearbox as well), the 5 Series Sedans will maintain their coverage within the segment. Here are some key advantages of the new 5 Series models over their key competitors:

Audi A6. Consisting of six variations (five of them with all-wheel drive), the A6 range is presently

comparable to that of the 5 Series although not precisely squared-off model-for-model. Audi sold 24,372 A6 models in calendar '02, far short of the 5 Series' 40,842, and is presently laying a strategy for increasing its volume. Dating from 1999, facelifted for 2002 and slated to be replaced during 2004, the present A6 generation is notable for its smooth styling. Its base model, a front-wheel-drive sedan with a 3.0-liter, 221-hp V-6 engine, is priced at \$36,360 including destination charge (about \$2,000 below the current 525i Sedan); the top A6 model, a sedan with 4.2-liter/300-hp V-8 and all-wheel drive, is priced at \$48,460 or about \$4,000 below the automatic-transmission 540i Sedan. Here's how the new 5 Series promises to compare with the most comparably positioned A6 models.

Key 525i advantages over Audi A6 Sedan¹:

- Inline 6-cylinder engine, vs. V-6. Though a balance shaft damps its inherent vibrations, Audi's 90° V-6 is subjectively less pleasant-sounding than BMW's inline six.
- Standard 6-speed manual transmission. Audi offers this model only with an automatic.
- Available 6-speed automatic transmission, vs. Audi's "multitronic" (continuously variable) transmission. Although the CVT is an interesting concept, its long-term reliability and durability are not yet proven in widespread customer use.
- As of 3/04 production, the 525i will offer a 6-speed Sequential Manual Gearbox as well². In Europe, Audi has introduced a "double-clutch" transmission with similar benefits, but U.S. plans for this feature are not known.
- Rear-wheel drive, vs. Audi's front-wheel drive. Although FWD offers some benefit in winter traction, BMW's RWD remains optimum for sporty, enjoyable handling.
- Rain-sensing windshield wipers (not available on A6)

1 – Comparison based on competitor's 2003 model.
2 – SMG available only in combination with Sport Package.

Market outlook

- Adaptive brakelights (not available on A6)
- Flat Tire Monitor (not available on A6)
- Power tilt/telescopic steering wheel, vs. manual
- Standard moonroof
- Greater shoulder room (by 0.9 in. front/1.5 in. rear)
- BMW Full Maintenance for 4 years/50,000 miles (Audi: scheduled maintenance only)
- Available 525i options not offered for A6:
 - Sport Package, including Active Steering, Active Roll Stabilization and run-flat tires
 - Active Cruise Control
 - Adaptive feature for available Xenon headlights (Audi offers Xenon but not the Adaptive feature)
 - Front and rear Park Distance Control; Audi's system is only for the rear
 - Head-up Display
 - Navigation System with DVD technology and Voice Command System (Navigation System not offered on base A6 Sedan or Avant quattro wagon)
 - Logic 7 audio system (Audi offers Bose system)
 - Sirius Satellite Radio
 - Heated rear seats

(Leather upholstery is standard in the A6. This model also available in quattro all-wheel-drive form for \$1,750 extra.)

For 530i vs. Audi A6 2.7T quattro AWD, add or substitute¹:

- Aluminum engine construction, vs. Audi's cylinder heads only (2.7-liter twin-turbo V-6 has cast-iron block)
- BMW gets power the "natural" way, vs. Audi's twin turbochargers. "When you push this Audi's pedal, something happens almost instantly," noted *Car and Driver* in a March '03 seven-car comparison test. "The problem: In a tick or two of time, way more happens than you want. For example, on corner exit, you call for power, then quickly find yourself backing off, then pressing down again."

- Available 6-speed automatic transmission, vs. Audi's 5-speed (multitronic not offered in this model)
- Navigation System with DVD technology and Voice Command System, vs. Audi's CD database and no Voice Command System.

(Compared to the base A6 Sedan, the 2.7T quattro adds a standard 6-speed manual transmission, all-wheel drive and sport suspension.)

For 545i vs. Audi A6 4.2 quattro AWD, add or substitute¹:

- Larger (4.4- vs. 4.2-liter) V-8 engine; Valvetronic and steplessly variable intake system also contribute to higher power (325 hp, vs. 300) and torque (330 lb.-ft., vs. 295).
- Available 6-speed manual or automatic transmission or SMG; Audi offers this model only with a 5-speed automatic.
- Standard 17-in. wheels and tires, vs. 16-in. standard, 17-in. in Sport Package.

(The A6 4.2 quattro AWD has standard all-wheel drive, premium leather upholstery, wood interior trim, power rear/manual rear side-window sunshades, heated power tilt/telescopic steering wheel, moonroof and 3-function transceiver. The 545i has standard Xenon Adaptive headlights, leather upholstery and wood interior trim.)

Infiniti M45. Marketed as a sort of "modern musclecar" in the U.S., the M45 is derived from an established Japanese-market Nissan model called the Cedric. Typically for Japanese models developed mainly for the home market, the Cedric/M45 has bland styling and an interior that might be characterized as "overdecorated." However, rather than the V-6 engine choices offered in Japan, it has the 4.5-liter V-8 engine from the Infiniti Q45, so it offers a lot of performance for its \$42,845 list price. Yet the *Wall Street Journal*, in its February 28, 2003 issue, characterized the M45 this way: "It may have more speed per dollar than a BMW, but the M45 doesn't match the German car's balance of agility and power."



Marketed as a sort of "modern musclecar," the Infiniti M45 was new for '03. The M45 seems to be a sort of "niche model": in the first four months of '03, only 1,347 units were sold in the U.S. (5 Series: 6,385 units).

This price pits the M45 against the current BMW 530i; indeed *Car and Driver* included both models in its comparison test. The 530i came in a very close 2nd to the new Mercedes E320; the M45 came in 5th despite its strong engine performance (0-60 mph in 5.7 sec.) As the M45 is new for '03, the following comparison should hold for '04.

Key 530i advantages over Infiniti M45¹:

- Available 6-speed manual or automatic transmission or SMG; Infiniti offers the M45 only with a 5-speed automatic.
- Likely superior fuel economy. EPA ratings for '03 models are 18/26 for the automatic-equipped 530i, 17/23 for the M45. In comparable driving of its own, the magazine got 22 mpg in the BMW, 18 in the Infiniti.
- Handling. *Car and Driver* awarded the '02 530i 9 points, equal to the best in its comparison test. The M45 earned just 7 points. "At first, we were uneasy with the feel of the controls – too much *artificial flavor added* [italics theirs]. And too much pancake syrup in the rack and pinion." We can expect the new 530i to widen this advantage.
- An important aspect of BMW's handling is optimum weight distribution (51.1% front/48.9% rear with automatic transmission), here aided by BMW's new aluminum front-end structure. M45 weight distribution is a less favorable 54.6%/45.4%.
- BMW's suspension is essentially all-aluminum, contributing to its supple ride and tenacious roadholding.
- 5 Series steering, even without the Sport Package's Active Steering, is bound to be better than Infiniti's "artificial flavor."
- More maneuverable. The E60's turning circle is just 37.5 ft., vs. M45's 40.0.
- Brakes. Here too, the magazine rated the '02 530i superior to the M45, and here too, the '04 5 Series is improved over the '03.
- Dynamic Stability Control. Amazingly, the M45 includes traction control and ABS, but doesn't offer stability control.
- Far more interesting, distinguished exterior design. *Car and Driver* said the M45 exterior "looks like one of those *anycars* [again, italics theirs] patched together for bank ads."
- Rain-sensing windshield wipers (not available on M45)
- Adaptive brakelights (not available on M45)
- More tasteful interior design. *Car and Driver* described the M45 cabin this way: "Orange markings on a black instrument panel look like Halloween decorations; LCD logic is determinedly obtuse..."
- Probably greater front head room. Infiniti gives 39.8 in. for the front, but that is likely without moonroof. Of the M45, *Car and Driver* commented that "With the optional sun [moon] roof, the ceiling crowds down in an unwelcome way."
- Standard moonroof
- Greater shoulder room (by 2.6 in. front/3.1 in. rear)
- Greater rear head room (by 0.8 in.)
- Greater rear leg room (by 3.5 in.). *Car and Driver* commented that the M45's "Rear-seat space and comfort are good for two but near the back of the pack for three." And this was against the '03 530i; the '04 back seat is significantly roomier.

- Standard 10-way power front passenger's seat, vs. 4-way
- The C/D comparison test rated the '02 530i better than the M45 on driver comfort, ergonomics, features and amenities, and fit and finish. Again, we expect the '04 530i to widen BMW's advantages here.
- Available 530i options not offered for M45:
 - Sport Package, including Active Steering, Active Roll Stabilization and run-flat tires
 - Active Cruise Control
 - Adaptive feature for available Xenon headlights (Xenon lights standard on M45, but the Adaptive feature is not available)
 - Front and rear Park Distance Control (not available on M45)
 - Head-up Display
 - Logic 7 audio system. The M45 comes standard with a 225-watt/7-speaker Bose system, but Logic 7's higher power and 13 speakers mean audiophile sound quality.

(M45 standard equipment includes 18-in. wheels/tires, leather upholstery and wood interior trim.)

Jaguar S-Type. Parallel to the 5 Series, the S-Type is Jaguar's middle sedan series; no wagon is offered. Its original debut was in 2000; only two years later it got a facelift, a larger V-8 engine, a 6-speed automatic transmission, an additional high-performance model, improved suspension and many other detail improvements. (And with good reason, as early S-Types were fraught with drawbacks and problems³.) The three models are the V-6, with 3.0-liter engine and '03 base price of \$42,495 including destination (\$700 above the '03 530i); the V-8 at \$49,975 (about \$2,500 below the '03 540i) with 4.2-liter engine; and the \$62,400 R, with supercharged 4.2-liter V-8. U.S. sales volume in calendar '02 was 15,965 units, vs. the 5 Series' 40,842. No major changes are expected for '04.

Key 530i advantages over Jaguar S-Type V-6:

- Inline 6-cylinder engine, vs. V-6. Though the Jaguar engine is claimed to be more powerful (240 hp) than BMW's 225-hp engine, it's derived from Ford's Duratec V-6 and doesn't deliver the performance one would expect from its power rating. In a comparison test in its March '03 issue, *Car and Driver* reported that the S-Type V-6 took 1.2 sec. longer to reach 60 mph, earned lower ratings for its engine and transmission, and came in last vs. the 530i's ultra-close 2nd.
 - Every E60 model will be available with a 6-speed manual, 6-speed automatic or 6-speed Sequential Manual Gearbox². The S-Type V-6 offers only a 5-speed manual and an automatic – essentially the same 6-speed unit as in the BMW, though with Jaguar's traditional "J-pattern" shifter rather than (we think) the more pleasant +/- manual shifting of BMW's STEPTRONIC.
 - Standard rain-sensing windshield wipers (S-Type 3.0: Premium Package)
 - Flat Tire Monitor (not available on S-Type)
 - Standard moonroof
 - Greater shoulder room (by 2.8 in. front/3.5 in. rear)
 - Greater rear head room (by 1.5 in. with Jaguar's moonroof)
 - BMW Full Maintenance for 4 years/50,000 miles (Jaguar: scheduled maintenance only)
- Available 530i options not offered for S-Type V-6:
 - 6-speed Sequential Manual Gearbox
 - Active Steering, Active Roll Stabilization and run-flat tires (Sport Package)
 - Adaptive feature for available Xenon headlights (Jaguar offers Xenon but not the Adaptive feature)
 - Front and rear Park Distance Control (rear-only standard on S-Type)
 - Head-up Display
 - Logic 7 audio system (Jaguar offers premium system, but not fully comparable with Logic 7)
 - Sirius Satellite Radio
 - Glove-compartment-mounted CD changer; Jaguar's is in trunk
 - 20-way power Comfort front seats with Active Head Restraints
 - Heated rear seats
 - Power rear/manual rear-side sunshades

(The S-Type V-6 has standard split folding rear seats and wood interior trim.)

For 545i vs. Jaguar S-Type V-8, add or substitute¹:

- Larger (4.4- vs. 4.2-liter) V-8 engine; Valvetronic and steplessly variable intake system also contribute to higher power (325 hp, vs. 293) and torque (330 lb.-ft., vs. 303)
- Available 6-speed manual transmission or SMG². Jaguar offers this model only with a 6-speed automatic.

(This Jaguar model adds standard moonroof and auto-dimming inside/exterior mirrors; the 545i also has standard auto-dimming mirrors as well as standard Xenon Adaptive headlights, leather upholstery and wood interior trim.)

Lexus GS. Like the Jaguar S-Type, this middle Lexus line comes in two models, a 6-cylinder and a V-8. The current GS generation was introduced in '98 and got a detail update in '01 that included a larger (4.3-liter) V-8 engine for the now so-named GS 430. Lexus sold 17,246 GS models in calendar '02, down a sharp 29.5% from '01. A new generation of this series is expected in '04.

Key 530i advantages over Lexus GS 300¹:

- Though the GS 300 has an inline 6-cylinder engine, it's a very old design. BMW's six has an aluminum cylinder block (GS 300: cast iron), which helps the 530i achieve better weight distribution: 51.1% front/48.9% rear with automatic transmission, vs. Lexus' less favorable 53.0/47.0. The 530i engine delivers 225 hp, vs. the GS 300's 220. And BMW's engine has chain-driven camshafts, vs. Lexus' timing belt that must be periodically replaced.
- BMW's transmission choices trump Lexus completely: 6-speed manual, automatic or SMG, vs. Lexus' 5-speed automatic only.
- Aluminum suspension system
- Standard 17-in. wheels and tires (not available on GS 300)
- Flat Tire Monitor (not available on GS 300)
- Rain-sensing windshield wipers (not available on GS)
- Adaptive brakelights (not available on GS)



Jaguar facelifted the S-Type for 2003, uncommonly soon after its debut in 2000. So far in '03, however, it has not achieved a significant sales gain. This is the supercharged R model.

1 – Comparison based on competitor's 2003 model.
 2 – SMG available only in combination with Sport Package.
 3 – A long-term test (62,000 miles) by Germany's *auto motor und sport* magazine documents this statement in great detail. Its conclusion: "In the context of the updates [for 2002], Jaguar promises that pretty much all criticized points have been corrected. Let's hope so."

Market outlook

- Auto tilt-down mirror for backing up (not available on GS)
- Driver's-seat, steering-wheel and exterior-mirror memory (GS 300: included in Leather Trim Package)
- Front and rear Head Protection System, vs. Lexus' front-only curtain head protection
- Available 530i options not offered for GS 300:
 - Sport Package, including Active Steering, Active Roll Stabilization and 17-in. run-flat tires
- Active Cruise Control
- Adaptive feature for available Xenon headlights (Lexus offers Xenon but not the Adaptive feature)
- Front and rear Park Distance Control; Audi's system is only for the rear
- Head-up Display
- 20-way power Comfort front seats
- Sirius Satellite Radio
- Heated rear seats
- Power rear/manual rear-side sunshades



As Lexus' middle series, the GS competes directly with the 5 Series; in '04, it will continue to do so, and may also appear in a new generation for the new model year. So far, though it has achieved much more success

than its predecessor, it's nowhere near the 5 Series, having sold only about 42% of the BMW's volume during calendar '02 (admittedly without any wagon models).



Lincoln LS is facelifted and improved for '03, and it achieves almost as much sales volume as the 5 Series with only two models (and several trim variations). It can also be said to

be "a lot of car for the money." But a March '03 *Car and Driver* comparison test shows that it's nowhere near the E39 530i – and the E60 6-cylinder models will be even better.

Lincoln LS. With 39,775 units sold in '02, Lincoln's "import fighter" achieved almost as much volume as the 5 Series. In the first two months of '03, sales were up slightly (by 3.2%) despite considerable improvements – more power, sharpened handling, improved interior and audio system, even improved build quality. And yet...

At \$40,995, the V-8 model in Sport form is priced at about \$900 under the '02 530i, but not to worry: it misses the E39 mark by a kilometer, and will miss the E60's by a mile. Indeed, in that March '03 *Car and Driver* comparison, the LS V-8 came in 6th vs. the 530i's 2nd-by-a-hair even though it accelerates more strongly.

Key 530i advantages over Lincoln LS V-8:

- BMW's transmission choices trump Lincoln completely: 6-speed manual, automatic or SMG, vs. Lincoln's 5-speed

automatic only. And Lincoln's automatic is "less satisfying than it might be," according to *Car and Driver*. "It dreads the thought of downshifts, pausing and sighing and making pouty 'If I must!' gestures..." BMW automatic transmissions are just the opposite: responsive, obedient and optimally calibrated for energetic driving.

- Aluminum suspension system for uncommonly supple ride and handling.
- Handling. The *Car and Driver* rated LS handling at 8 points, the 530i's at 9. "On the road," the magazine commented, "the 'Sport' Lincoln has a heavy-footed way over imperfect surfaces. You hear every impact of the tires as the thumps and bumps jar the car's bones. Little shakes are transmitted up through the structure; you feel them in the steering wheel, and you hear little rattles."

- Standard Dynamic Stability Control. The LS V-8 Sport comes standard with traction control and ABS; stability control is a \$735 option.
- Adaptive brakelights (not available on LS)
- Flat Tire Monitor (not available on LS)
- Front and rear Head Protection System (not available in LS)
- Standard moonroof
- Greater rear head room than with Lincoln's moonroof (by 1.2 in.)
- Available 530i options not offered for LS V-8:
 - Active Steering, Active Roll Stabilization and run-flat tires (Sport Package)
 - Active Cruise Control
 - Adaptive feature for Xenon headlights: Lincoln offers Xenon lights, but not the Adaptive feature.
 - Front and rear Park Distance Control (LS: rear only)
 - Head-up Display
 - Logic 7 audio system: Lincoln's standard Alpine Audiophile system is good, but Logic 7 is an industry leader in audiophile sound.
 - 20-way power Comfort front seats
 - Sirius Satellite Radio

(The LS V-8 Sport comes standard with machined wheels, leather upholstery and aluminum interior trim.)

Mercedes-Benz E-Class. The only new-generation competitor right now, the '03 E-Class comes in V-6 E320 (\$47,615) and V-8 E500 (\$55,515) Sedans (the latter replacing the previous E430), plus an E320 Wagon in rear- and all-wheel-drive versions. The Sedans have about the same interior space as before, so Mercedes' margin in this area shrinks with the 5 Series' growth in rear-seat room. The E-Class is the "volume leader" in this segment, selling 42,598 units in '02 or about 4% more than the 5 Series.

(The GS 300 has standard auto-dimming inside/exterior mirrors, wood interior trim, 3-function transceiver, moonroof and CD changer.)

For 545i vs. Lexus GS 430, add or substitute:

- Larger (4.4- vs. 4.2-liter) V-8 engine; Valvetronic and steplessly variable intake system also contribute to higher power (325 hp, vs. 300) and torque (330 lb-ft., vs. 325).
- Fully sport-equipped 6-Speed model; although Lexus offers 17-in. wheels/tires on this model, there's still no Sport Package, manual transmission or SMG.

(The GS 430 adds Xenon headlights, memory system and leather upholstery; the 545i adds standard Xenon Adaptive headlights, leather upholstery and wood interior trim.)



Despite relatively high prices, the Mercedes-Benz E-Class is the volume leader in the mid-luxury segment. It appeared in a new generation for '03, and got off to a strong start. Yet recent consumer surveys show

that Mercedes-Benz is experiencing unprecedented quality shortfalls, and this could adversely affect all Mercedes sales in the future.

Key 530i advantages over Mercedes-Benz E320 Sedan¹:

- Inline 6-cylinder engine, vs. V-6. Like Audi's, the Mercedes V-6 has a balance shaft to tame its 90° vibrations; it's smooth enough but lacks the wonderful sound of BMW's inline 6. And it has only 3 valves per cylinder, so despite being larger, it delivers less power (221 hp vs. 225) than the 530i engine.
- Every E60 model will be available with a 6-speed manual or automatic transmission or Sequential Manual Gearbox. The E-Class offers only a 5-speed automatic.
- Standard 17-in. wheels and tires (E320: Sport Package)
- Spare tire included in standard equipment (E-Class: no spare, kit for temporary tire repair included)
- Superior steering and braking feel are a likely E60 advantage. In the March '03 comparison test, *Car and Driver* reported that the new E-Class has "an incredible amount of computer manipulation of the brakes and steering and in its throttle response. All of that is much less successful than the computer's suspension interventions. The steering effort goes up at times, to a degree not anticipated by the driver. Moreover, crosswinds produce exceptionally large force variations at the wheel rim when you're trying to hold the car straight. Brake response is nonlinear, seeming to increase retardation midway to a stop sign. And sometimes throttle

response at very low speeds is so soggy we thought the brake was on."

- BMW Full Maintenance for 4 years/50,000 miles (Mercedes-Benz: scheduled maintenance only)
- Standard moonroof
- Available 530i options not offered for Mercedes-Benz E320:
 - Active Steering, Active Roll Stabilization and run-flat tires (Sport Package)
 - Head-up Display
 - Sirius Satellite Radio
 - Heated rear seats

(The E320 has standard auto-dimming inside/exterior mirrors, leather upholstery, wood trim, 3-function transceiver and rear side-impact airbags. Mercedes offers a self-leveling Semi-Active Air Suspension system as a \$1,575 option, but not in combination with the Sport Package.

For 545i vs. Mercedes-Benz E500, add or substitute¹:

- Despite Mercedes' larger (5.0- vs. 4.4-liter) V-8 engine, BMW delivers more power: 325 hp,

vs. 302. Credit BMW's 4 valves per cylinder, Valvetronic and steplessly variable intake system.

(The E500 adds standard 4-zone climate control, more extensive leather upholstery, Semi-Active Air Suspension and 17-in. wheels/tires; the 545i also has standard 17-in. wheels and tires, leather upholstery and wood interior trim plus moonroof.)

Volvo S80. This old-generation series, Volvo's largest car line, was introduced in '99 and has evolved relatively little since. For '04, the S80 gets an exterior and interior facelift, improved steering and optional "4C" electronically controlled suspension. The series adds an all-wheel-drive model that, oddly, adopts the 2.5-liter, 208-hp turbocharged 5-cylinder engine from the S60 and V70 series. Otherwise, the 6-cylinder S80 models continue: the 2.9, priced at \$37,730, with 194-hp inline 6-cylinder engine; and the T6 (\$45,210), with a turbocharged 2.8-liter version of this engine producing 268 hp. A more luxurious Premier version of the T6 is priced at \$49,200; the '04 line went on sale in April '03. Volvo sold only 15,361 S80s in '02, down nearly 25% from '01. A successor is expected for '05, rumored to share its platform with a replacement for the Ford Taurus.

Key 525i advantages over Volvo S80 2.9:

- Though the S80 has an inline 6-cylinder engine, it's positioned transversely and drives the front wheels; this arrangement results in a relatively large turning circle, torque steer and nose-heavy weight

distribution (57.0% front/43.0% rear, vs. 525i's optimum 50.2/49.8). The current 525i is already a better-balanced, better-handling car; the new, with its full aluminum front end, will be even more so.

- Standard 6-speed manual transmission, 6-speed automatic or (as of 3/04 production) Sequential Manual Gearbox². Even in '04, Volvo offers this model only with a 4-speed automatic!
- Aluminum suspension system
- Dynamic Stability Control standard, vs. optional
- Standard front foglights (neither standard nor on S80 2.9 option list)
- Rain-sensing windshield wipers standard; optional on S80 as part of Climate Package
- Adaptive brakelights (not available on S80)
- Flat Tire Monitor (not available on S80)
- Power tilt/telescopic steering wheel, vs. manual
- Standard moonroof
- BMW Full Maintenance for 4 years/50,000 miles (Volvo: scheduled maintenance only, 3 years/36,000 miles)
- Available 525i options not offered for S80 2.9:
 - Sport Package, including Active Steering, Active Roll Stabilization and run-flat tires
 - Active Cruise Control
 - Xenon Adaptive headlights
 - Front and rear Park Distance Control (Volvo: rear only)
 - Head-up Display
 - Logic 7 audio system
 - 6-disc CD changer (Volvo's is 4-disc)
 - Auto-dimming inside/exterior mirrors in 525i Premium Package; auto-dimming inside mirror standard in S80, exterior not available
 - 20-way power Comfort front seats
 - Heated rear seats
 - Sirius Satellite Radio

(The S80 2.9 has a standard 3-function transceiver.)



2004 Volvo S80 is now on the market, with facelift and modest improvements. An all-wheel-drive model (with 5-cylinder engine) is offered in Europe but not yet in the U.S. The

U.S. line continues to consist of the 2.9 (base model), T6 (higher-performance model with turbocharged engine) and T6 Premier (high-luxury version with turbo engine).

¹ - Comparison based on competitor's 2003 model.
² - SMG available only in combination with Sport Package.

For 530i vs. Volvo S80 T6, add or substitute:

- The T6's extra power doesn't change the fundamentals. "Maybe because the [T6] displayed tasteful curves instead of frumpy 90-degree angles, some expected it to perform sports-car maneuvers, as do similarly priced BMWs. It didn't," opined *AutoWeek* in its December 11, 2000 issue.
- Unlike the S80 2.9, the T6's automatic transmission (still a 4-speed) has Geartronic, which permits manual shifts. But Germany's *auto motor und sport* (May 5, 1999) faulted "imprecise" movement of the shifter into its manual mode, and too-frequent automatic shifting in highway driving. BMW's STEPTRONIC provides more precise shifter movements.

(The T6 adds standard 17-in. wheels/tires, front foglights, leather upholstery, moonroof and Dynamic Stability Traction Control, which is similar to BMW's standard Dynamic Stability Control; Volvo's On Call Plus, similar to BMW Assist, is also standard on the T6 though optional on the 2.9.)

For 545i vs. Volvo S80 T6 Premier, add or substitute:

- The T6 Premier retains the regular T6's 6-cylinder, turbo-charged T6 engine (268 hp, 280 lb-ft. torque), while the 545i is powered by a much more potent, torquey V-8 with 325 hp and 330 lb-ft. There's truly no comparison here!
- The 545i comes in two versions: standard with 6-speed automatic transmission, 6-Speed with Sport equipment. The automatic version can also be ordered with the Sport Package, and the 6-Speed can be ordered with BMW's Sequential Manual Gearbox (SMG). The S80 T6 Premier is strictly a luxury model, offering none of these choices; the T6 is Volvo's only S80 sport model.

(The T6 Premier adds distinctive wheels, metallic paint at no extra cost, Climate and Premium Packages, upgraded carpeting, heated rear seats, extended rear seat cushions, power rear-window sunshade, rear coolbox, a rear-seat entertainment system with two monitors, wider-opening rear doors, and various other luxury details; the 545i adds standard Xenon Adaptive headlights, leather upholstery and wood interior trim.)

Who are our target customers?

The new 5 Series will be marketed as an automobile for the typical BMW customer, who –

- loves to drive
- is technologically savvy
- is self-confident
- leads an active lifestyle
- has practical needs that are addressed by a midsize sedan.

On this last point, the increased rear-seat and trunk space will extend the 5 Series' appeal to

the more "rational" buyers, giving it enhanced conquest potential for current Mercedes and Volvo owners. In this sense Volvo, with by far the highest percentage of "young families" in the segment (see table), is a target to move somewhat toward – but not to match, as BMW doesn't want to dilute its own character.

Launching the new 5 Series

Production of the E39 5 Series ends at the beginning of June '03, and an orderly runout of E39 production is facilitated by product measures taken for the '03 model year: standard moonroofs added to the 6-cylinder models, very appealing new Sport Packages for the V-8s and DVD technology for the optional Navigation System.

Production of U.S. 530i models begins in 7/03; the 525i and 545i follow in 9/03. Other key events are planned as follows:

- Ride-and-drive event for Center principals and personnel – July '03. To be held in Germany.

- Central Train the Trainer, Mid-Ohio Raceway, Columbus, Ohio; August 14-16
- Central training event, Mid-Ohio Raceway, Columbus, Ohio; August 18-23
- Eastern training events, Summit Point Raceway, Summit Point, West Virginia; August 23-29, September 3-8
- Western training event, Firebird Raceway, Phoenix, Arizona; September 3-13
- Southern training event, Texas Motor Speedway, Fort Worth, Texas; September 15-24.

Further events are being developed. For the latest details of the Marketing Plan, contact Martin Birkmann, 5/X5 Series Product Manager, at [REDACTED]

Current demographics for the 5 Series and its competitors

	BMW 5 Series	Audi A6	Jaguar S-Type	Lexus GS	Mercedes-Benz E-Class	Volvo S80	Mid-Luxury Segment
Gender							
Male	72.1%	66.3%	49.7%	65.5%	66.4%	56.8%	63.8%
Female	27.9%	33.7%	50.3%	34.5%	33.6%	43.2%	36.2%
Pre-family (no children, under 45)							
Pre-family	23.4%	7.6%	5.1%	17.8%	10.2%	9.8%	12.4%
Post-family (no children, 45+)							
Post-family	43.9%	61.2%	79.0%	57.9%	63.7%	50.9%	57.1%
Younger family (oldest child 1-12 yr.)							
Younger family	15.0%	16.6%	7.0%	13.1%	17.5%	25.3%	17.4%
Older family (oldest child 13-17 yr.)							
Older family	17.8%	14.6%	8.9%	11.2%	8.6%	14.1%	13.1%
Median age	47	52	57	53	55	52	52
Total median family pre-tax income, \$							
Total median family pre-tax income, \$	162,501	164,102	133,334	127,633	145,857	139,202	140,818
Education							
College graduate	42.2%	29.6%	32.9%	36.0%	32.5%	25.3%	30.8%
Some post-graduate	7.3%	11.3%	9.9%	10.8%	11.1%	11.8%	10.8%
Post-graduate degree	29.4%	39.5%	28.0%	25.2%	28.9%	35.0%	33.4%
Total college	78.9%	80.4%	70.8%	72.1%	70.8%	72.2%	75.1%
Ethnic group							
African American	2.9%	0.9%	8.9%	7.5%	9.2%	6.6%	5.4%
Hispanic	2.9%	0.6%	1.9%	5.7%	3.3%	0.0%	2.3%
Asian American	13.6%	1.4%	1.9%	11.3%	12.9%	3.9%	7.2%
White/Caucasian	78.6%	96.7%	83.5%	72.6%	73.7%	85.8%	82.8%
Other	1.9%	0.4%	3.8%	2.8%	0.9%	3.6%	2.2%

Current demographic reveal some interesting facets of the 5 Series customer base:

- It has the highest percentage of male buyers in its segment.
- The largest proportion of its buyers is in the "pre-family," but also in the "older family" and "post-family" lifestages.

- Its median age is the youngest.
- It includes the highest proportion of college graduates, though not of post-graduates and total college-educated persons.
- It has a relative low proportion of African-American buyers, but the highest proportion of Asian-Americans.